



Getinge Lancer Ultima labware washing systems

Freestanding series

This document is intended to provide information to an international audience outside of the US.

GETINGE 



Professional cleaning results

– integrated systems,
repeatable results

From quality control to general laboratory research, Getinge Lancer Ultima series washers meet space and budget requirements in laboratories performing a range of critical applications where clean labware is essential.

Typical applications include analytical chemistry, quality control, pharmaceutical and environmental science laboratories, wastewater treatment, food and beverage analysis, public health and consumer product testing facilities.

The exclusive Prolux programmable microprocessor controller commands a full range of prewash, wash, rinse and drying functions through simple touchscreen menus on all Ultima series washers. The convenience of five preset programs for light to heavy loads simplifies operation, while more complex programs can be customized whenever needed to meet specific applications.



Getinge Lancer Ultima model 1300 LX freestanding labware washer, shown with accessory loading rack, sold separately.



Quiet Operation
Noise reduction design minimizes sound for quiet operation.



Cool Surface
High-performance insulation contains heat and limits energy consumption.



Prolux programmable microprocessor controller with intuitive touchscreen user interface.

Control screen shows actual cycle performance, alarm events. Data is captured for documentation and communication.

Preset or user programmed cycles are fully adjustable to permit multiple combinations of prewash, wash, rinse, acid rinse, purified final rinse, HEPA filtered forced air drying, controlled duration, temperature and more.

High efficiency powerful fluid circulation with direct fluid path and rear manifold connections deliver optimal pressure and flow rates.

Chamber walls made in durable AISI 316L stainless steel material.

Injector jet performance provides inside out wash and rinse functions.

Stainless steel top and bottom spray arms and multiple levels of injection washing ensure thorough spray coverage.

Two integrated automatic chemical dosing pumps are standard on all models. Convenient on-board chemical storage beneath chamber saves space.



View-In-Process Window

An optional View-In-Process (VIP) window includes an interior LED light for visual verification of the interior load during the cycle.

Getinge Lancer Ultima model 1400 LXP freestanding labware washer, shown with accessory loading rack, sold separately.

Meeting a variety of laboratory needs

The Getinge Lancer Ultima series freestanding washers include six high-performance models that offer a range of labware loading options using baskets, injector racks or combination racks for the best high capacity processing of multiple labware types in the industry.



910 LX / 1300 LX / 1400 LX features	1400 LXP / 1600 LXP features
Prolux control interface	Prolux Plus control interface
Manual fold down door	Manual fold down door
Forced-air drying, injectors, HEPA filtered	Forced-air drying, injectors, HEPA filtered

Capacity comparison					
Model	Volume	Interior (W x H x D)	Positions	Wash levels	Configurations
910 LX	160 L (5.7 cu. ft.)	535 x 544 x 520 mm (21.1" x 21.4" x 20.5")	3	2	3
1300 LX	180 L (6.4 cu. ft.)	535 x 644 x 520 mm (21.1" x 25.4" x 20.5")	4	3	5
1400 LX / 1400 LXP	304 L (10.7 cu. ft.)	626 x 773 x 629 mm (24.6" x 30.4" x 24.8")	4	3	6
1600 LXP	408 L (14.4 cu. ft.)	703 x 858 x 678 mm (27.7" x 33.8" x 26.7")	5	4	12
1600 LXP/HE	500 L (17.7 cu. ft.)	703 x 1048 x 678 mm (27.7" x 41.3" x 26.7")	5	4	12

Models shown (left to right) 910 LX, 1300 LX, 1400 LX, 1400 LXP, 1600 LXP and 1600 LXP/HE. View-In-Process (VIP) window is an optional feature.

Small spaces, impressive capacity

910 LX

Drawings display front and side of unit, with door swing allowance.

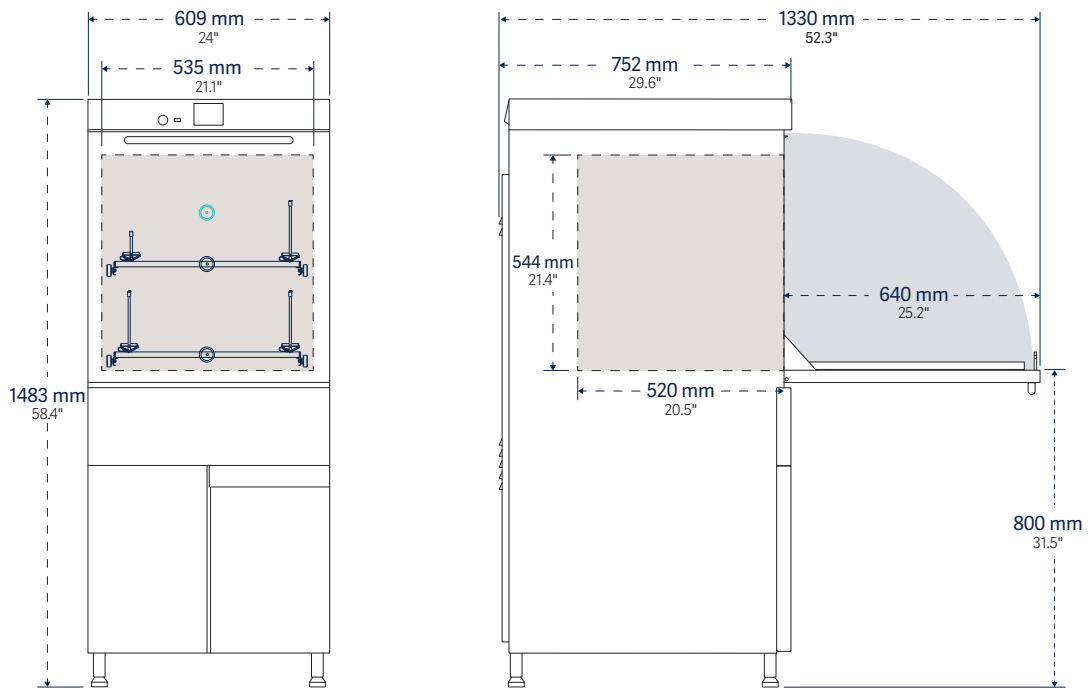

Model	Interior dimensions W x H x D	Exterior dimensions W x H x D	Water per fill* L (gal)	Programs presets	custom
910 LX	535 x 544 x 520 mm 21.1" x 21.4" x 20.5"	609 x 1483 x 752 mm 24" x 58.4" x 29.6"	13 (3.4)	5	35

* Total water consumption per fill based on reservoir sump and all fluid path fill volumes, care should be taken when evaluating comparative water consumption claims.



910 LX
3.5" Prolux Control Interface,
Standard Monitoring.



Stainless steel top and bottom spray arms on all models ensure complete washing and rinsing of glassware exterior and interior of large mouthed glassware.



910 LX

Wash load configurations

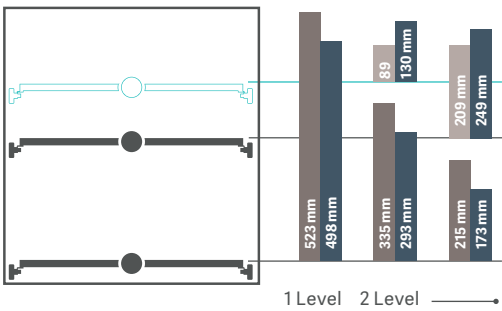

PST Basic basket
 IXC / IXL injection racks (long / short jets)
 PSBT Basic basket with spray arm



Sound Level
<60 dB(A)

Model	Cycle function				Drying	Chemical dosing			Net weight Empty kg (lb)	
	Wash temp. max. °C (°F)	Rinse purified water	Rinse acid			Automatic pumps	On-Board chemical storage	Level sensors		Water softener
910 LX	95°C (203°F)	■	■		Forced-air chamber and in- jectors; HEPA filtered	2 (max 3)	■	2 (max 3)	□	143 (315)

■ / □ Standard / optional features

Compact footprint, lasting impression

1300 LX

Drawings display front and side of unit, with door swing allowance.

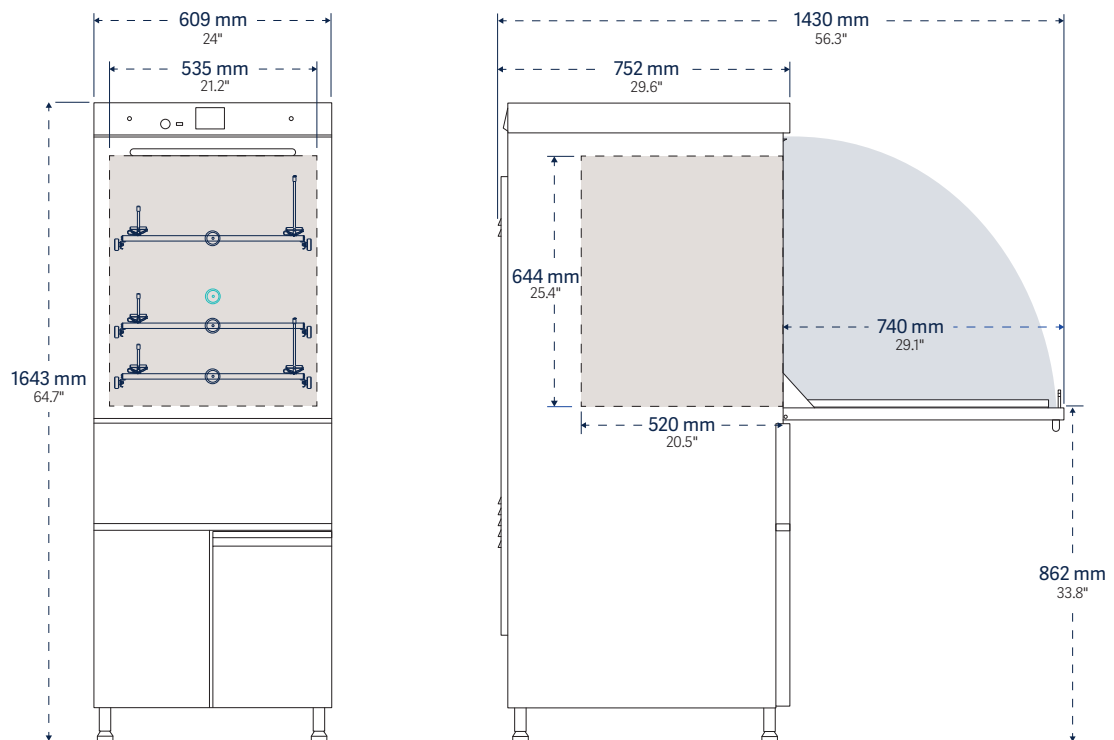

Model	Interior dimensions	Exterior dimensions	Water per fill*	Programs	
	W x H x D	W x H x D		presets	custom
1300 LX	535 x 644 x 520 mm 21.1" x 25.4" x 20.5"	609 x 1643 x 752 mm 24" x 64.7" x 29.6"	15 (4)	5	35

* Total water consumption per fill based on reservoir sump and all fluid path fill volumes, care should be taken when evaluating comparative water consumption claims.



3.5"
 **1300 LX**
 3.5" Prolux Control Interface,
 Standard Monitoring.



For maximum connectivity, all Ultima series washers include a USB port, conveniently located on the front panel for easy access and transfer of cleaning process documentation, including cycle parameters, cycle number, date and time, phase duration, temperature for each phase, and detergent and acid intake.



1300 LX
 Wash load configurations

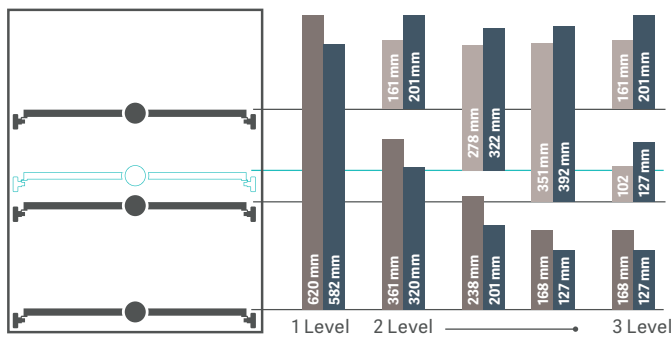

PST Basic basket
 IXC / IXL injection racks (long / short jets)
 PSBT Basic basket with spray arm



Sound Level
 <60 dB(A)

Model	Cycle function				Chemical dosing				Net weight Empty kg (lb)
	Wash temp. max. °C (°F)	Rinse purified water	Rinse acid	Drying	Automatic pumps	On-Board chemical storage	Level sensors	Water softener	
1300 LX	95°C (203°F)	<input checked="" type="checkbox"/>	<input checked="" type="checkbox"/>	Forced-air chamber and in- jectors; HEPA filtered	2 (max 3)	<input checked="" type="checkbox"/>	2 (max 3)	<input type="checkbox"/>	145 (319)

/ Standard / optional features

Space efficiency, multi-level loading

1400 LX / 1400 LXP

Drawings display front and side of unit, with door swing allowance.

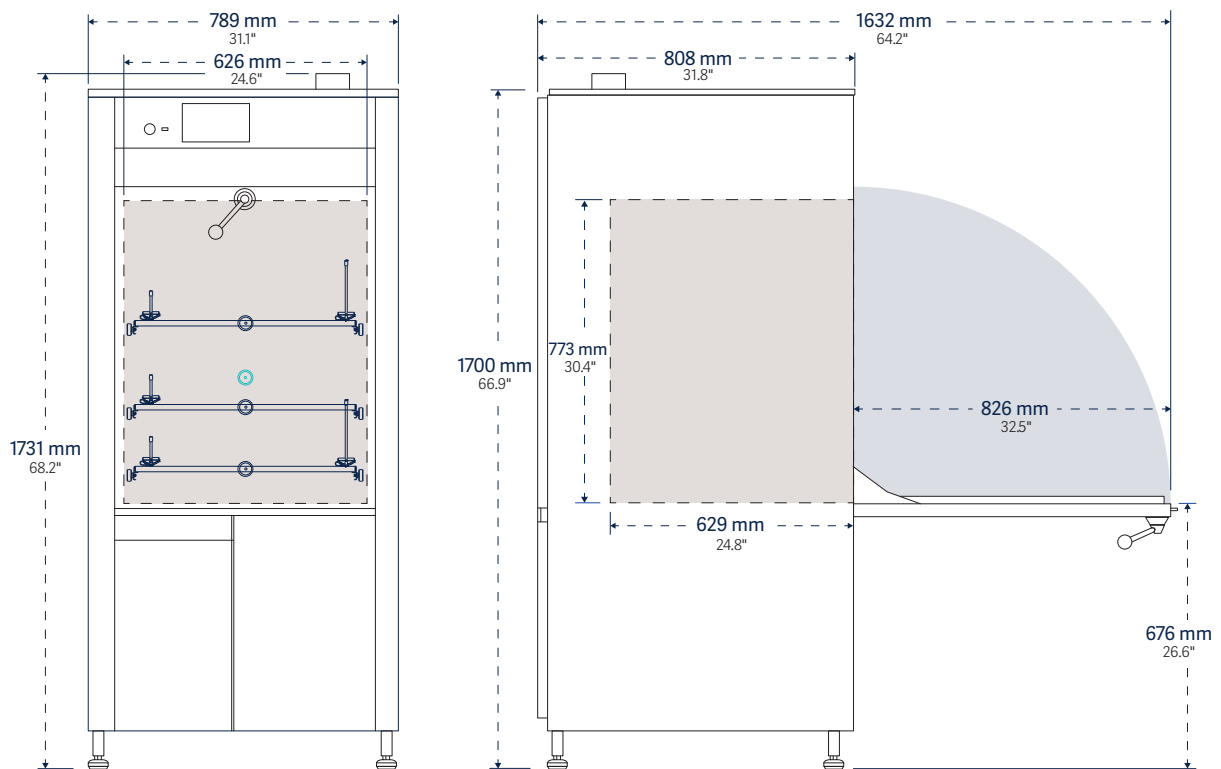

Model	Interior dimensions	Exterior dimensions	Water per fill*	Programs	
	W x H x D	W x H x D		presets	custom
1400 LX 1400 LXP	626 x 773 x 629 mm 24.6" x 30.4" x 24.8"	789 x 1731 x 808 mm 31.1" x 68.2" x 31.8"	20-25 (5.2-6.6)	5	35

* Total water consumption per fill based on reservoir sump and all fluid path fill volumes, care should be taken when evaluating comparative water consumption claims.



3.5" **1400 LX**
3.5" Prolux Control Interface,
Standard Monitoring.

7" **1400 LXP**
7" Prolux Plus Control Interface,
Enhanced Monitoring.

All Ultima series labware washers feature telescopic runners with advanced design for smooth and easy function as well as innovative rack stops for safety and ergonomics.



1400 LX / 1400 LXP
Wash load configurations

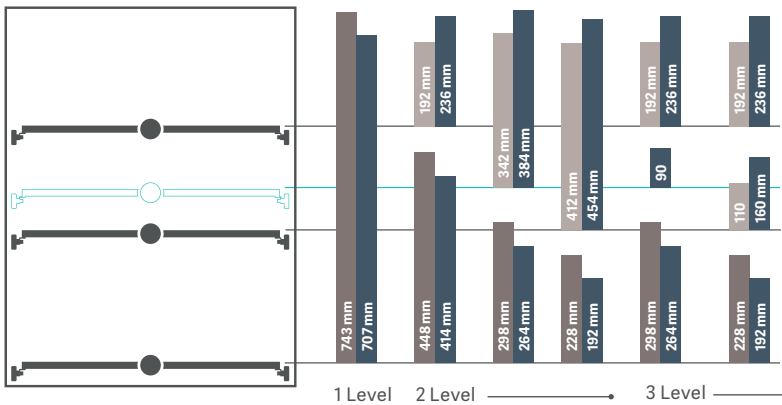

■ PST Basic basket ■ IXC / IXL injection racks (long / short jets)
■ PSBT Basic basket with spray arm



Sound Level
<69 dB(A)

Model	Cycle function				Chemical dosing				Net weight Empty kg (lb)
	Wash temp. max. °C (°F)	Rinse purified water	Rinse acid	Drying	Automatic pumps	On-Board chemical storage	Level sensors	Water softener	
1400 LX 1400 LXP	95°C (203°F)	■	■	Forced-air chamber and in- jectors; HEPA filtered	2 (max 3) 2 (max 4)	■	2 (max 3) 2 (max 4)	□	213 (469)

■ / □ Standard / optional features

Maximum flexibility

1600 LXP

Drawings display front and side of unit, with door swing allowance.

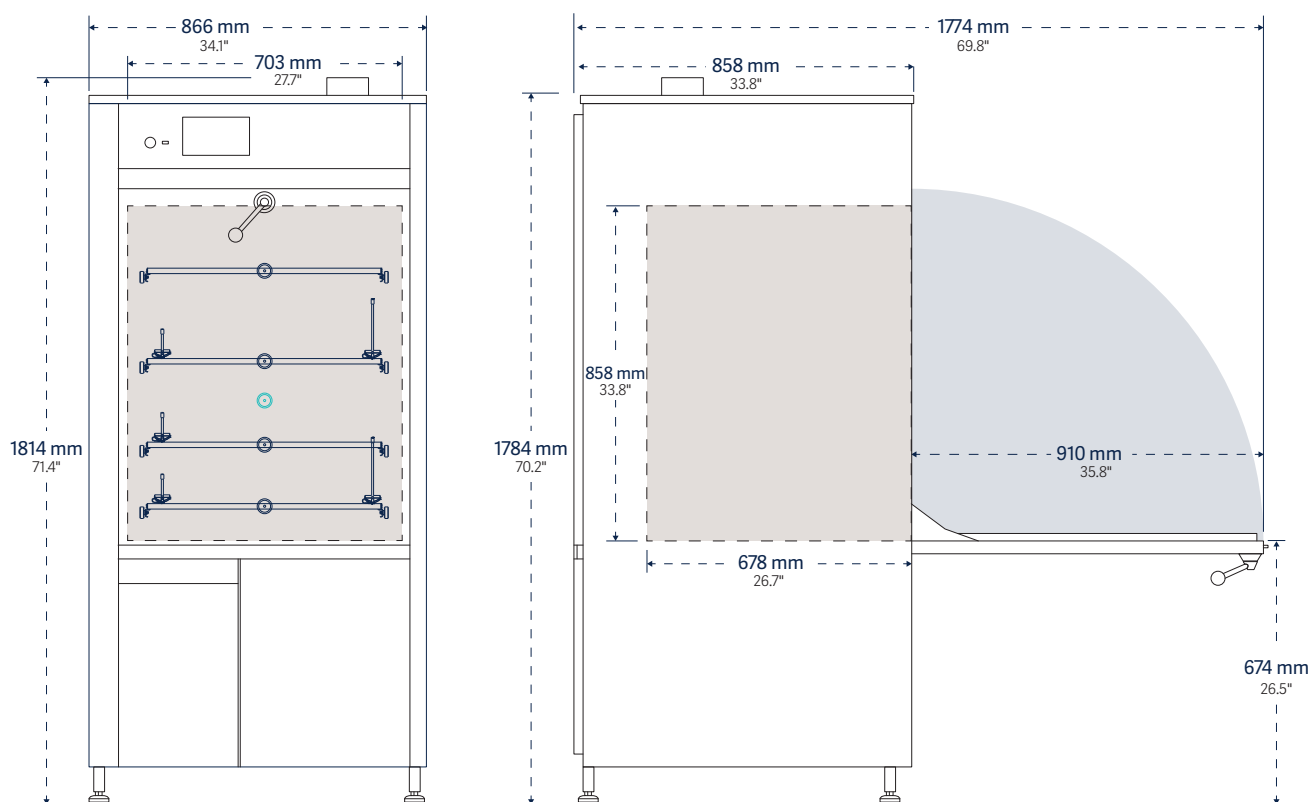

Model	Interior dimensions	Exterior dimensions	Water per fill*	Programs	
	W x H x D	W x H x D		presets	custom
1600 LXP	703 x 858 x 678 mm 27.7" x 33.8" x 26.7"	866 x 1814 x 858 mm 34.1" x 71.4" x 33.8"	30-35 (7.9-9.2)	5	35

* Total water consumption per fill based on reservoir sump and all fluid path fill volumes, care should be taken when evaluating comparative water consumption claims.



1600 LXP
7" Prolux Plus Control Interface,
Enhanced Monitoring.



1600 LXP
Wash load configurations.

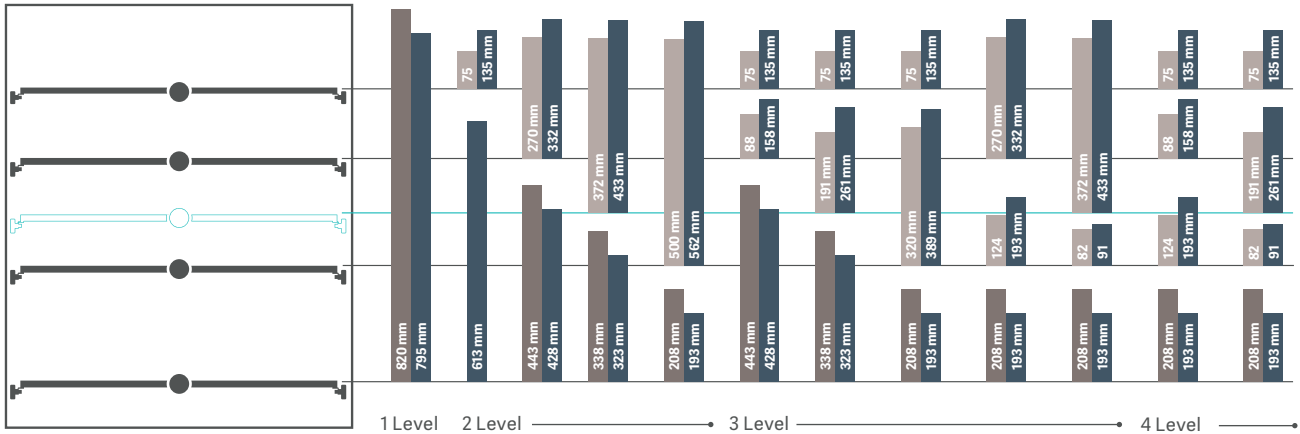

■ PST Basic basket
■ PSBT Basic basket with spray arm

■ IXC / IXL injection racks (long / short jets)

Sound Level <69 dB(A)

Model	Cycle function			Drying	Chemical dosing			Water softener	Net weight Empty kg (lb)
	Wash temp. max. °C (°F)	Rinse purified water	Rinse acid		Automatic pumps	On-Board chemical storage	Level sensors		

1600 LXP 95°C (203°F) ■ ■ Forced-air chamber and injectors; HEPA filtered 2 (max 4) ■ 2 (max 4) □ 215 (474)

■ / □ Standard / optional features

High throughput

1600 LXP/HE

Drawings display front and side of unit, with door swing allowance.

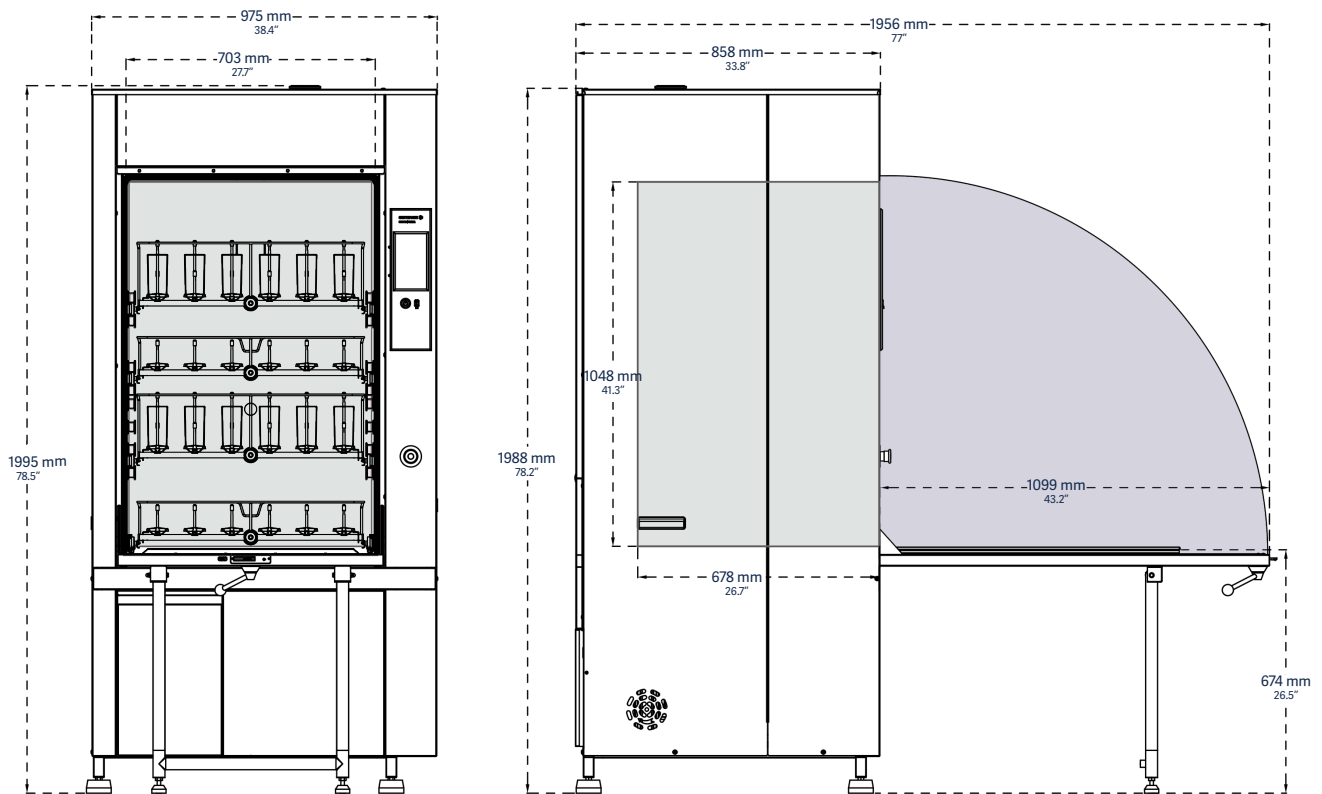

Model	Interior dimensions	Exterior dimensions	Water per fill*	Programs	
	W x H x D	W x H x D		presets	custom
1600 LXP/HE	703 x 1048 x 678 mm 27.7" x 41.3" x 26.7"	975 x 1995 x 858 mm 38.4" x 78.5" x 33.8"	30-35 (7.9-9.2)	5	35

* Total water consumption per fill based on reservoir sump and all fluid path fill volumes, care should be taken when evaluating comparative water consumption claims.



1600 LXP/HE



High throughput chamber with a total loading capacity of 500 liters (17,7 cu.ft)

Include door jacks for safe loading and unloading

1600 LXP/HE

Wash load configurations.

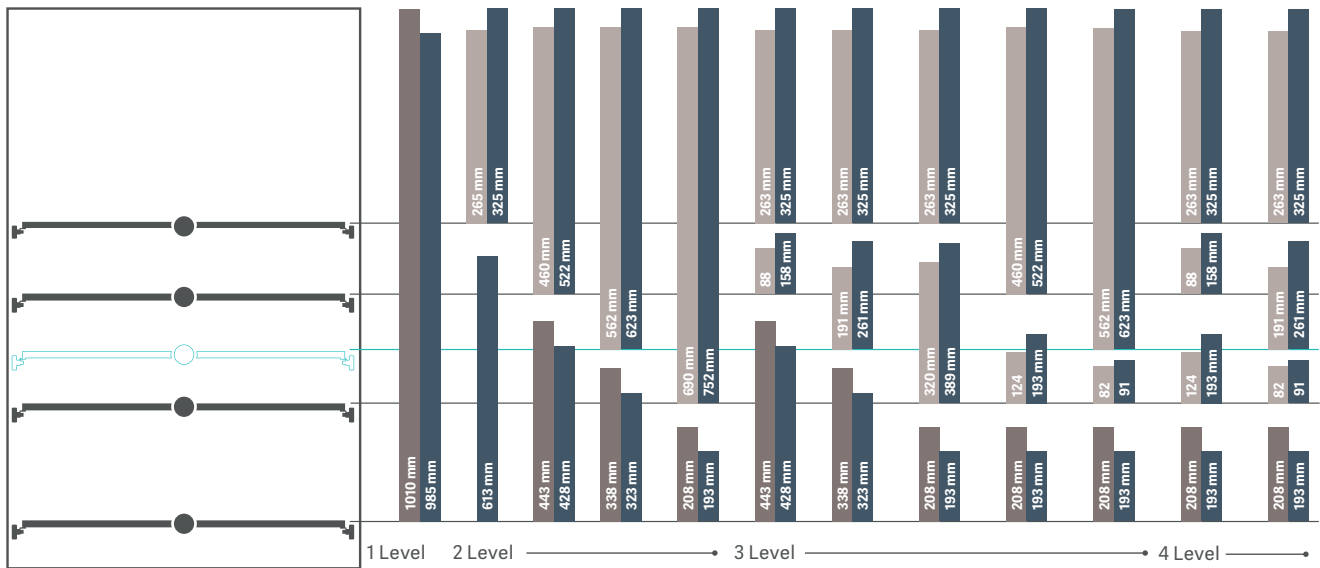

■ PST Basic basket
■ PSBT Basic basket with spray arm

■ IXC / IXL injection racks (long / short jets)

Sound Level <69 dB(A)

Model	Cycle function				Chemical dosing				Net weight
	Wash temp. max. °C (°F)	Rinse purified water	Rinse acid	Drying	Automatic pumps	On-Board chemical storage	Level sensors	Water softener	Empty kg (lb)
1600 LXP/HE	95°C (203°F)	■	■	Forced-air chamber and injectors; HEPA filtered	2 (max 4)	■	2 (max 4)	□	215 (474)

■ / □ Standard / optional features

Repeatable results

– with reliability, safety and high throughput

Ergonomic loading configurations.

Unlike oversized washers with less efficient loading patterns, Getinge Lancer Ultima series freestanding labware washers are designed for high-density loading and the most effective use of available interior space. This efficiency maximizes throughput and reduces capital investments, operating costs and the amount of dedicated lab space needed.

- Telescoping load-bearing rails permit extension of racks for easy loading with or without an optional trolley.
- All racks are interchangeable between wash levels thereby minimizing the need for additional accessories.
- Racks for Getinge Lancer Ultima series undercounter models and freestanding models 910 LX, 1300 LX are interchangeable.
- The fold-down door creates a platform for proper rack positioning and more comfortable loading and unloading.

Cleaning performance and safety.

Operating systems are designed for performance, efficiency and high throughput.

- An automatic door lock prevents door opening during active cycles and protects the user from heat and chemical exposure.
- Top and bottom stainless steel spray arms are pressurized to provide exterior coverage to the labware.
- Injector rack manifold connections are located at the rear for proper alignment and the most efficient pressure and flow.
- Washing temperature can be set to a maximum of 95°C (203°F) if required for more difficult soils.
- Automatic Peristaltic pumps are self-contained for accurate and repeatable dosing of detergents or acids required by each cycle.
- Multiple DI rinses can be programmed to eliminate interior and exterior spotting.



The front-loading door folds down to create an ergonomically stable platform for proper rack positioning and easier loading, eliminating the need for a trolley to load or unload glassware.

Alarms and monitoring

- The high resolution touchscreen color display is easy to read from a distance.
- The intuitive graphic user interface creates a series of visual performance indicators such as active program, time remaining, warning, alarm and cycle completed functions.
- Five preset programs permit one touch operation. Additional cycles are programmed from the graphic user interface.
- An integrated USB port allows easy front panel access for process tracking and data logging. Optional process record printouts available through USB or Ethernet ports are managed by the Prolux controller.

Construction

The sump, spray arms, interior chamber walls and door are fabricated from 316L stainless steel to resist aggressive chemicals and residues.

- Exterior 304L stainless steel panels resist corrosion, simplify cleaning and protect electrical and plumbing components.
- Double-wall insulated assembly confines heat loss and minimizes noise.
- Easy access stainless steel chamber filters extend washer life by protecting pumps and interior plumbing from debris.
- A compact liquid sump and direct fluid path minimizes water volume per fill, lowers overall consumption per cycle and improves sustainability throughout the useful life.

Hydraulic design

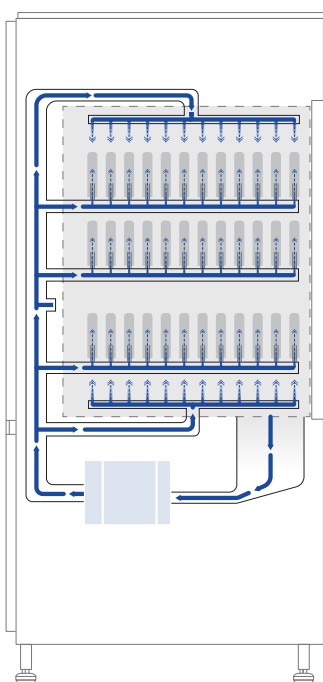

The Getinge Lancer Ultima hydraulic design optimizes pressure and flow for efficient performance at all wash levels.

The combination of a high-performance recirculation pump, straight-line fluid path and center-mounted rack interface assures maximum water flow through spray arms and injectors.

Washer pump is protected from debris by a stainless steel sump screen. The screen lifts out without tools for easy cleaning.

Model 1400 LXP, waterflow.

View-In-Process

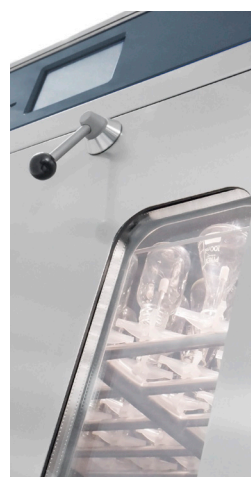

An optional dual pane View-In-Process (VIP) window includes an interior LED light for visual verification of the interior load during the cycle. The light is activated by the On/Off switch through the Prolux controller. Tempered safety glass provides excellent sound and heat abatement and enhances operator safety. Factory installed, specify when ordering.

Model 910 LX:

348 mm (13.7") H x 173 mm (6.8") W

Models 1300 LX / 1400 LX

1400 LXP / 1600 LXP:

508 mm (20") H x 173 mm (6.8") W

* VIP window not available on model 1600LXP/HE.

Simple, flexible, documented, trusted.

Prolux controller.

The all new 3.5" Prolux and 7" Prolux Plus controllers are based on a high-performance PLC microprocessor designed for simplicity, one-touch start, real-time status indicators and intuitive programming options that permit customization over the range of washer operations.

Both the Prolux and Prolux Plus controller integrate a suite of menu screens that support digital functions from cycle selection, process monitoring, warning advisories, audible and visual alarms, system communications and data capture.

Operation

- Screen menus and graphic user interfaces are designed to simplify setup and operations including active programs, remaining time, warnings, alarms and cycle complete notifications.
- Five preset programs are factory loaded for one-touch control of most routine applications.
- When additional cycle programs are desired, parameters can be changed through secure access to the administration screen where an intuitive graphic user interface displays all options.

Communication and connectivity

- A front-panel USB port simplifies direct connection to peripheral devices for cycle tracking and data capture. The port is covered by a protective hood.
- A real-time process record is printed if optional printer is installed.
- Multiple data ports include Ethernet and RS422 connectors.
- Optional printer documents cycle performance, warnings and alarms.



The Prolux and Prolux Plus (above) controllers include a touch-screen interface with a common icon directory that permits scrolling access to primary screens from the same menu. A set of sub-menu screens display additional icon directories specific to the screen functions.

910 LX / 1300 LX / 1400 LX



- 3.5" Prolux color touchscreen interface
- 320 x 240 pixel resolution display
- Five presets
- Additional custom program options

1400 LXP / 1600 LXP / 1600 LXP/HE



- 7" Prolux Plus color touchscreen interface
- 800 x 480 pixel resolution display
- Five presets
- Additional custom program options



The Prolux control interface features an intuitive menu of primary and secondary screens, configured with icons, to simplify access to all functions. The touchscreen is easily managed with a gloved hand.

Programming

Programmable cycle parameter selections include:

- **Prewash.** Up to 3 prewashes, 0 to 30 minutes each, temperatures up to 95°C (203°F), chemical dosing as desired.
- **Wash.** 0 to 30 minutes, temperatures up to 95°C (203°F), chemical dosing as desired.
- **Acid rinse.** 0 to 30 minutes, chemical dosing, temperatures up to 95°C (203°F).
- **Running water rinses.** One or more short rinse sequences after the wash or rinse cycle purge the hydraulic circuit of residual detergent and rinsing agents.
- **Rinse, DI.** Up to 4 rinses, 0 to 30 minutes each. Ambient to 95°C (203°F).
- **Final rinse, DI.** 0 to 30 minutes, temperatures up to 95°C (203°F).
- **Drying.** Up to 90 minutes, adjustable. Temperature, ambient to 110°C (230°F), Prolux Plus models; ambient to 85°C (185°F), Prolux models.
- **Cooling.** 0 to 30 minutes, adjustable.

Display screens

Featured display screens are 3.5" screen. Displays for 7" screens are identical.

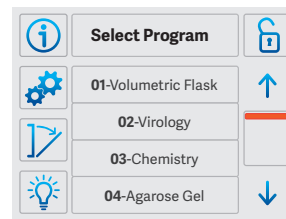

Program Selection.

The Program Selection screen lists the five factory presets, as well as additional presets added through administrator access.

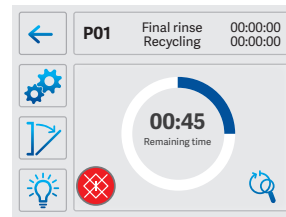

Cycle in Process.

A real-time status screen displays time remaining until cycle completion and links to cycle detail screens with the touch of a button.

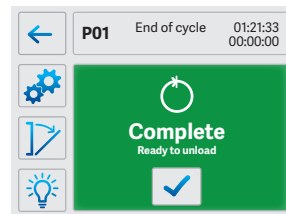

Cycle Completed.

The green Cycle Completed screen confirms completion of the cycle and indicates the washer is safe to unload.

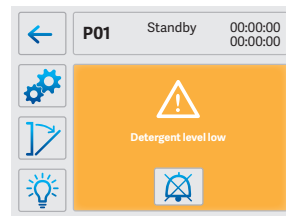

Warning Message.

The amber Warning Message screen provides a status report to prompt refill of detergent and rinse agents.

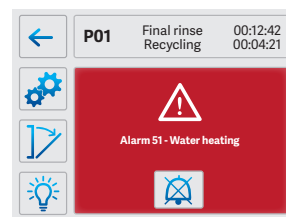

Alarm Message.

The red Alarm Message screen confirms the reason for a system shutdown and prompts corrective action needed in advance of a restart.

Comprehensive collection

– a perfect fit for any lab

Superior efficiency for needs small and large.

Getinge Lancer Ultima offers a full range of labware washers to improve throughput. Undercounter washers offer a range of performance features designed to deliver clean labware faster than other industrial washers. Undercounter washers are available in three configurations and two sizes with generous load capacities.

Getinge Lancer Ultima means superior quality

All models are produced to withstand harsh laboratory conditions, minimize water consumption and save energy. The complete line of Getinge Lancer Ultima labware

washers address applications at any capacity for high-density processing of multiple labware types.

All models feature the Prolux PLC microprocessor controller with color enhanced graphic user interface for intuitive one-touch cycle selection and start. The Prolux control functionality permits easy scale-up from smaller to larger models.

For more information on undercounter models please refer to the Getinge Lancer Ultima series undercounter brochure.

Getinge Lancer Ultima Series



*With side chemical cabinet (SCC)



Getinge Lancer Ultima model 810 LX undercounter labware washer, shown with accessory loading racks, sold separately.

Bioreactor preparation solution

– consistent processes deliver repeatable results

The expertise of Getinge and Applikon research and development has established a synergistic process for bioreactor preparation.

A solution to prevent cross-contamination, minimize any research downtime and ensure validated outcome through optimal processes and procedures. Getinge offers a specially designed bioreactor wash rack for Getinge Lancer Ultima laboratory washers.

This dedicated wash rack, for the Getinge Applikon multi-use bioreactors, establishes a highly reproducible system with significant benefits such as:

- Free-up resources to increase laboratory throughput and minimize downtime
- Decreasing operational labor costs compared to manual cleaning processes
- Improving staff safety by removing potential repetitive motions and exposure of harmful substances related to manual procedures.

The relationship between the bioreactor design and laboratory washer assures predictable outcomes.

The defined connection points on the wash rack and bioreactor head plate ensures a clean bioreactor prepared for sterilization.

Empty rack

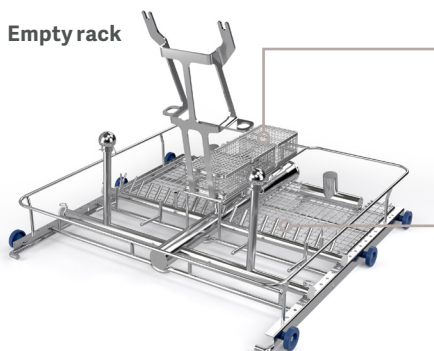

Baskets

Small bioreactor assembly parts are placed in the baskets to ensure that these are in place throughout the cleaning cycle.

Multiple injector tubes

Reassure best possible cleaning performance for each entry connection on the bioreactor head plate.

Bioreactors in place*

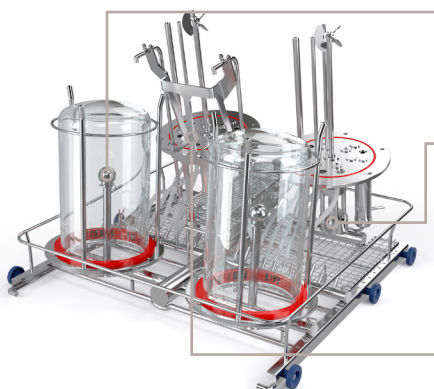

Spray headers

High flow of process water through the spray headers clean the inside of the bioreactor vessel.

Head plate fixation

The head plate is fixed in the wash rack. The spray wings within the washer will clean the outside of the head plate.

Angled head plate

Minimum water retention on the head plate surface will speed up the drying phase which shorten the overall process cycle.

*Multi-use, volume 1-3 liter



Getinge Lancer Ultima model 910 LX freestanding labware washer.

Adaptable to suit your application

Consumables

For best results, Getinge Lancer offers a selection of detergents and rinsing agents that have been tested and validated to maximize the performance of the Getinge Lancer Ultima washer while minimizing water consumption.

- Getinge Lancer LLL Detergent produces analytically clean results. It is phosphate free, fully biodegradable and will not harm aluminum, plastic or rubber.

A typical dose is from 6 to 10 ml per liter for water with hardness values between 200 and 400 ppm. Available in 10 liter container.

- The Getinge Lancer NLL Neutralizing agent is an acetic-acid based formulation ideal for the final rinse. The dose is typically 5 ml per liter. Available in 10 liter container.

Some options available

Features		910 LX	1300 LX	1400 LX	1400 LXP	1600 LXP	1600 LXP/HE
Discharge water cooling	Reduces effluent temperature to less than 60°C (140°F) for code compliant transfer to utility drain.	<input type="checkbox"/>	<input type="checkbox"/>	<input type="checkbox"/>	<input type="checkbox"/>	<input type="checkbox"/>	<input type="checkbox"/>
pH programming	Neutralizes effluent before transfer to utility drain.	<input type="checkbox"/>	<input type="checkbox"/>	<input type="checkbox"/>	<input type="checkbox"/>	<input type="checkbox"/>	<input type="checkbox"/>
Printer	For hard copy permanent record.	<input type="checkbox"/>	<input type="checkbox"/>	<input type="checkbox"/>	<input type="checkbox"/>	<input type="checkbox"/>	—
Emergency Stop	Emergency stop button.	<input type="checkbox"/>	<input type="checkbox"/>	<input type="checkbox"/>	<input type="checkbox"/>	<input type="checkbox"/>	<input checked="" type="checkbox"/>
Sampling Valve	Manual sampling valve.	<input type="checkbox"/>	<input type="checkbox"/>	<input type="checkbox"/>	<input type="checkbox"/>	<input type="checkbox"/>	<input type="checkbox"/>
Conductivity monitoring	Conductivity meter for final rinse verification.	<input type="checkbox"/>	<input type="checkbox"/>	<input type="checkbox"/>	<input type="checkbox"/>	<input type="checkbox"/>	<input type="checkbox"/>
Pump pressure monitoring	Verification that correct pump pressure is achieved in the water distribution system that secure optimal cleaning performance.	<input type="checkbox"/>	<input type="checkbox"/>	<input type="checkbox"/>	<input type="checkbox"/>	<input type="checkbox"/>	<input type="checkbox"/>
Water softener	Water softener.	<input type="checkbox"/>	<input type="checkbox"/>	<input type="checkbox"/>	<input type="checkbox"/>	<input type="checkbox"/>	<input type="checkbox"/>
Chemical dosing pump, additional	Additional chemical dosing pump. Up to 1 additional on 910 LX / 1300 LX / 1400 LX and up to 2 additional on 1400 LXP / 1600 LXP / 1600 LXP/HE.	<input type="checkbox"/>	<input type="checkbox"/>	<input type="checkbox"/>	<input type="checkbox"/>	<input type="checkbox"/>	<input type="checkbox"/>
Main Switch	Main power switch, shuts off all power to the washer.	—	—	<input type="checkbox"/>	<input type="checkbox"/>	<input type="checkbox"/>	<input type="checkbox"/>

* See product specifications for details and additional options to select.

/ Standard / optional features

Utilities		910 LX	1300 LX	1400 LX	1400 LXP	1600 LXP	1600 LXP/HE
Steam heating	Steam coil to utilize house steam for heating of wash/rinse water.	—	—	<input type="checkbox"/>	<input type="checkbox"/>	<input type="checkbox"/>	<input type="checkbox"/>
Low pressure kit	Boosts DI water supply input pressure to assure optimum performance.	<input type="checkbox"/>	<input type="checkbox"/>	<input type="checkbox"/>	<input type="checkbox"/>	<input type="checkbox"/>	<input type="checkbox"/>
Steam condenser	Steam condenser for collapsing exhaust vapor.	<input type="checkbox"/>	<input type="checkbox"/>	<input type="checkbox"/>	<input type="checkbox"/>	<input type="checkbox"/>	<input type="checkbox"/>
Gravity drain	For quick evacuation of chamber. Requires compressed air and floor drain.	—	—	—	<input type="checkbox"/>	<input type="checkbox"/>	<input type="checkbox"/>
Tri-clamp DI inlet	Direct DI water inlet with tri-clamp connection and dry contact for control of customer DI loop valve.	—	—	—	<input type="checkbox"/>	<input type="checkbox"/>	<input type="checkbox"/>

Construction		910 LX	1300 LX	1400 LX	1400 LXP	1600 LXP	1600 LXP/HE
Moving runners	Customized location of rack manifolds to accommodate specific loads.	—	—	—	<input type="checkbox"/>	<input type="checkbox"/>	<input type="checkbox"/>
Extended diptube kit	Extended diptubes for use with 125-208 L (33-55 gal) chemical containers.	—	—	<input type="checkbox"/>	<input type="checkbox"/>	<input type="checkbox"/>	<input type="checkbox"/>
Dry contact	Dry contacts for external communication.	<input type="checkbox"/>	<input type="checkbox"/>	<input type="checkbox"/>	<input type="checkbox"/>	<input type="checkbox"/>	<input type="checkbox"/>
Seismic restraints	Seismic tie down brackets.	<input type="checkbox"/>	<input type="checkbox"/>	<input type="checkbox"/>	<input type="checkbox"/>	<input type="checkbox"/>	<input type="checkbox"/>
Stainless steel plumbing	Complete stainless steel hydraulic circuit including main circulation pump.	—	—	—	<input type="checkbox"/>	<input type="checkbox"/>	<input type="checkbox"/>
View-In-Process window	Includes interior light, permitting visual verification during wash cycles.	<input type="checkbox"/>	<input type="checkbox"/>	<input type="checkbox"/>	<input type="checkbox"/>	<input type="checkbox"/>	—

* See product specifications for details and additional options to select.

/ Standard / optional features

Site preparation		910 LX / 1300 LX / 1400 LX / 1400 LXP / 1600 LXP / 1600 LXP/HE
Water supply (hot, cold and DI)	G 3/4" hose thread connection, recommended min. flow 20 L/min (5.25 gpm); lower flow rates may extend cycle times; 200 to 600 kPa (29-87 psi) water pressure	
Drain requirement, vertical standpipe	40 mm (1 1/2") diameter, 500 to 700 mm (20" to 27") above floor	
Certifications		

2006/42/EC

Common accessories

Choose from up to 60 different injector racks, pipette racks and baskets. All racks are interchangeable between the washer lower and upper levels.

- A wide variety of standard inventory baskets and injector racks are available to meet most needs.
- Custom racks and baskets can be fabricated to meet specific needs or special applications.

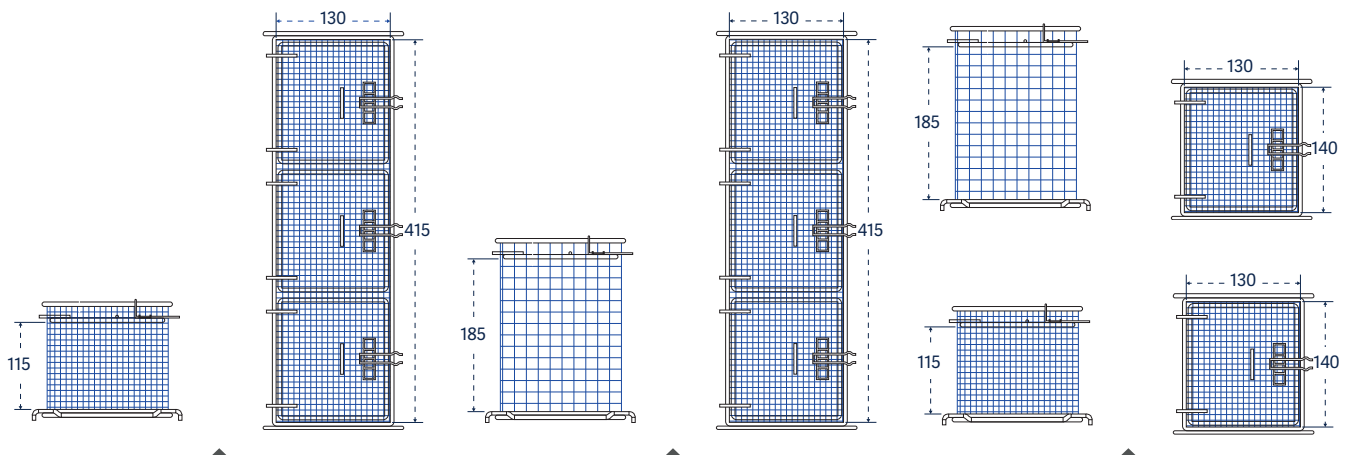

Small mesh basket with cover, long:
Catalog No. STCXL



Small mesh basket, tall with cover, long:
Catalog No. LTCXL



Small mesh baskets, tall and short:
Catalog No. LTC and STC

Small mesh baskets	910 LX / 1300 LX / 1400LXP / 1600LXP / 1600LXP/HE	Part number
For bottle caps, ferrules, plugs, stoppers and test tubes.		
Mesh basket, short, with cover, 130x118x98 mm	STC	02010037
Mesh basket, short, with cover, 405x118x98 mm	STCXL	02010038
Mesh basket, tall, with cover, 130x118x170 mm	LTC	02010029
Mesh basket, tall, with cover, 405x118x170 mm	LTCXL	02010030



Accessories

1600 LXP/ 1600 LXP/HE



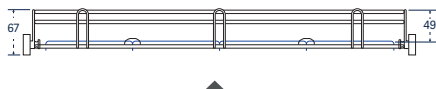

Basic basket with reversible tray lid:
Catalog No. PST and GC



Basic basket with spray arm: Catalog No.
PSBT



Basket for culture dishes: Catalog No. BP

Baskets		
Useful for beakers, trays, dishes, dissolution vessels, funnels, instruments and jars.	1600 LXP	Part number
Basic basket	PST 16	02600084
Basic basket with spray arm	PSBT 16	02600083
Support for culture plates for PST basket	20 PL	01030417
Basket covers		
Accessory basket covers are available to secure small or lightweight labware during the wash cycle.	1600 LXP	Part number
Reversible tray lid for PST/PSBT	GC 16	01030573
Reversible tray lid for injector racks	GCI 16	01030589

Short injectors For inside out cleaning of narrow neck glassware, bottles, cylinders, boiling flasks, Erlenmeyer flasks and volumetric flasks.	1600 LXP	Part number
36 short jets, 6 mm diameter	36 IXC 16	02600096
64 short jets, 6 mm diameter	64 IXC 16	02600100
100 short jets, 2 mm diameter	100 IXA 16	02600088
100 short jets, 6 mm diameter	100 IXC 16	02600090
100 short jets, mixed 2 mm and 6 mm diameter	100 IXA/2 16	02600089
144 short jets, 2 mm diameter	144 IXA 16	02600093
144 short jets, 6 mm diameter	144 IXC 16	02600095
144 short jets, mixed 2 mm and 6 mm diameter	144 IXA/2 16	02600094



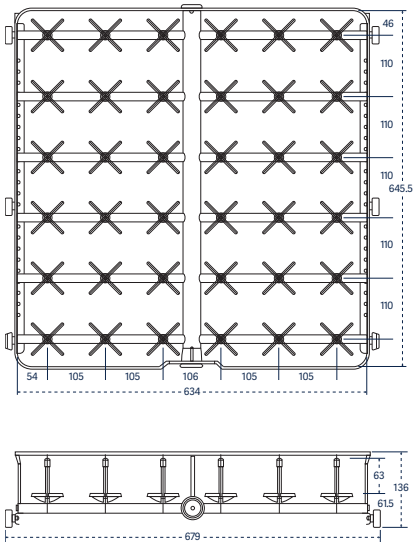

Catalog No. 36 IXC 16

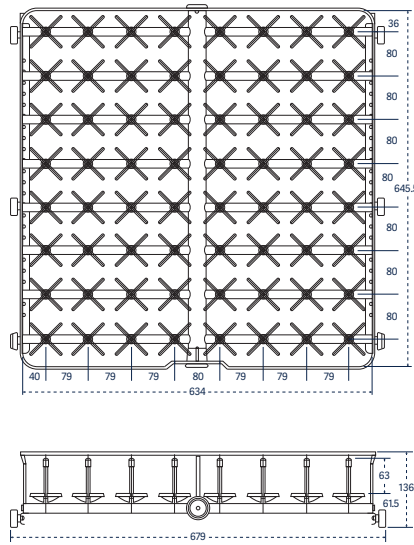

Catalog No. 64 IXC 16

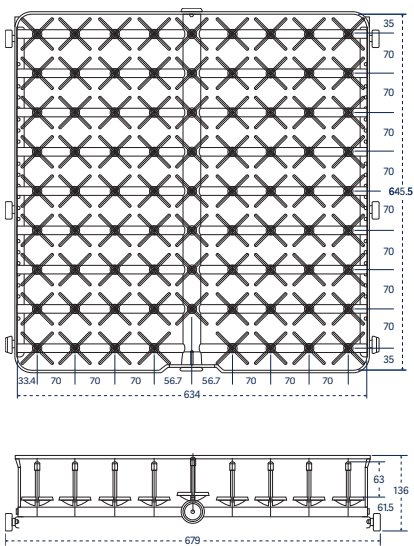

Catalog No. 80 IXC 16

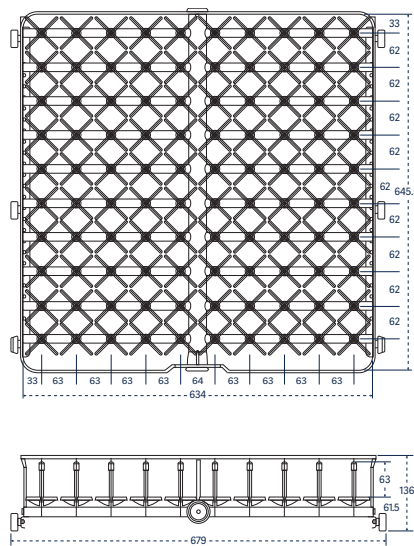

Catalog No. 100 IXA; IXC; IXA/2 16

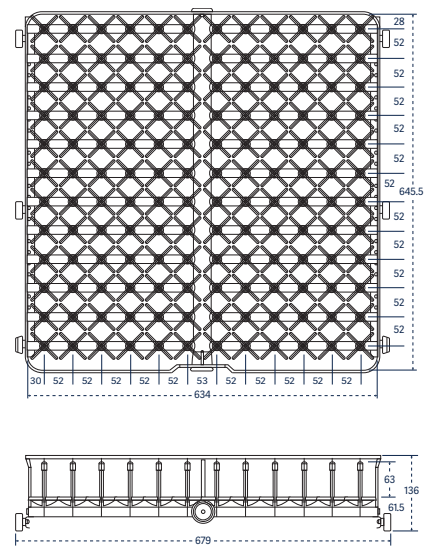

Catalog No. 144 IXA; IXC; IXA/2 16

Long injectors For inside out cleaning of large narrow neck glassware, bottles, cylinders, boiling flasks, Erlenmeyer flasks and volumetric flasks.	1600 LXP	Part number
5 long jets, 12.7 mm diameter, with spray ball	5 IXL 16	02600080
9 long jets, 12.7 mm diameter, with spray balls	9 IXL 16 DIFF	AA02600112
9 long jets, 12.7 mm diameter	9 IXL 16	02600081
12 long jets, 6 mm diameter	12 IXL 16	02600077
36 long jets, 6 mm diameter	36 IXL 16 D6	02600098
36 long jets, 8 mm diameter	36 IXLC 16 D8	02600097
64 long jets, 6 mm diameter	64 IXL 16	02600101
80 long jets, 6 mm diameter	80 IXL 16	02600104
100 long jets, 6 mm diameter	100 IXL 16	02600091

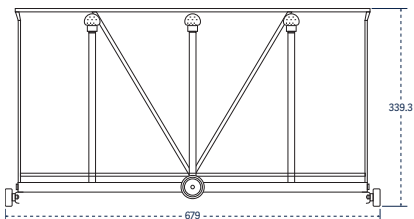
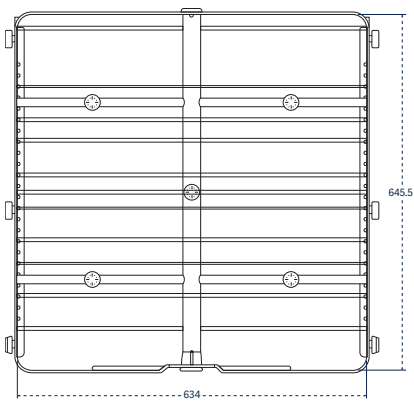

Catalog No. 5 IXL 16

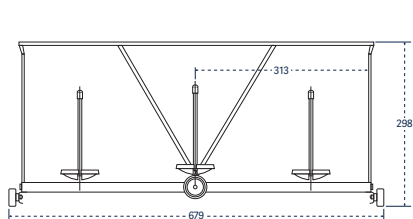
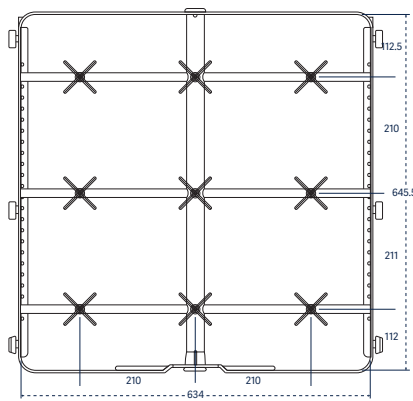

Catalog No. 9 IXL 16

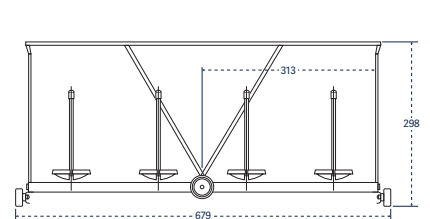
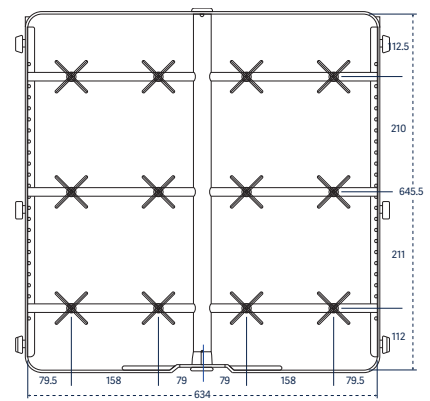

Catalog No. 12 IXL 16

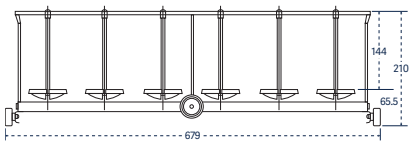
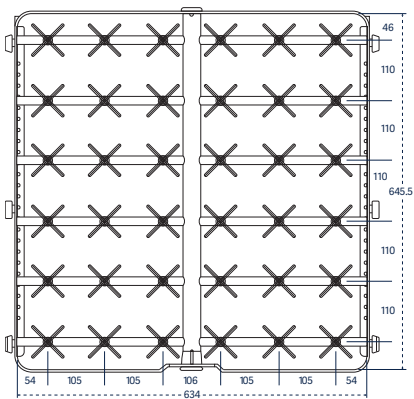

Catalog No. 36 IXL 16 D6

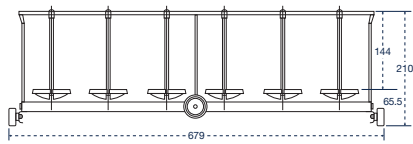
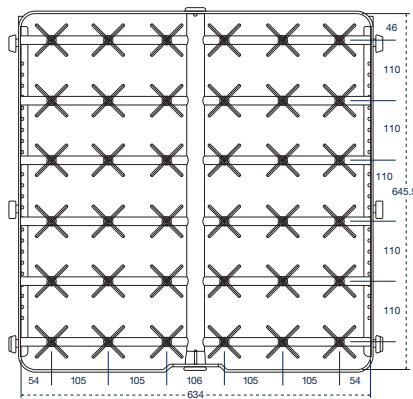

Catalog No. 36 IXL 16

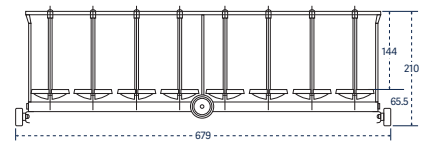
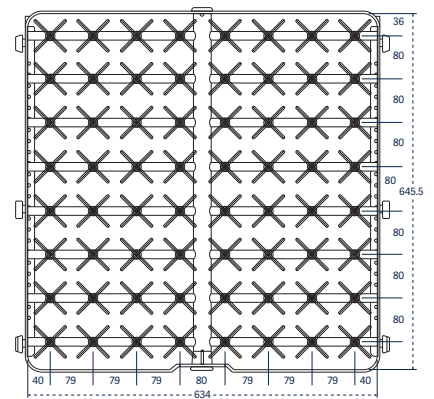

Catalog No. 64 IXL 16

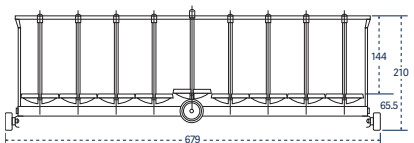
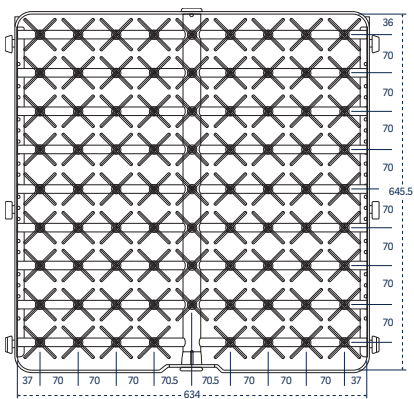

Catalog No. 80 IXL 16

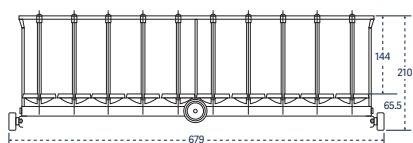
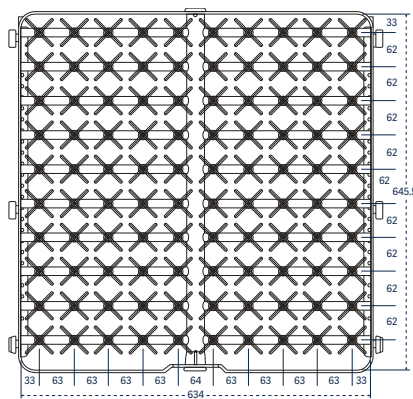

Catalog No. 100 IXL 16

Extra long injectors, 305 mm (12") tall

For inside out cleaning of narrow neck glassware, bottles, cylinders, boiling flasks, Erlenmeyer flasks and large volumetric flasks. **1600 LXP**

Part number

1 long jet, 12.7 mm diameter, with spray ball

1 IXL 16

02600076

2 long jets, 12.7 mm diameter, with spray ball

2 IXL 16

02600078

4 long jets, 12.7 mm diameter, with spray ball

4 IXL 16 DIFF

02600079

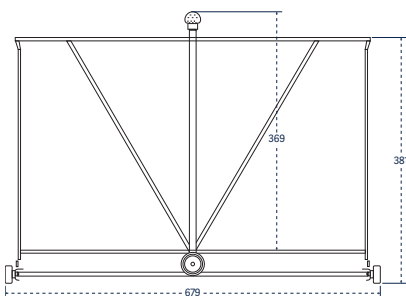
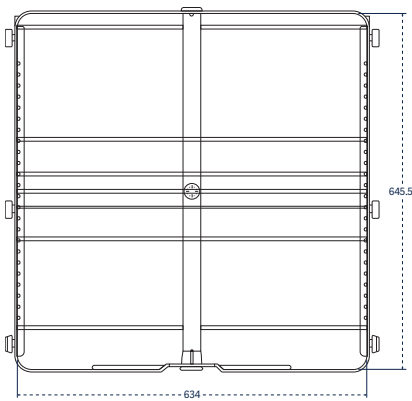

Catalog No. 1 IXL 16

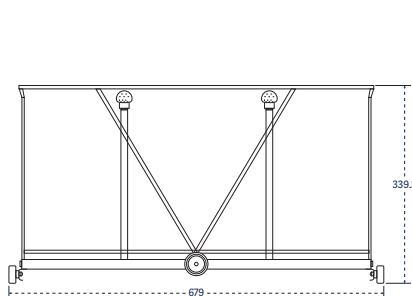
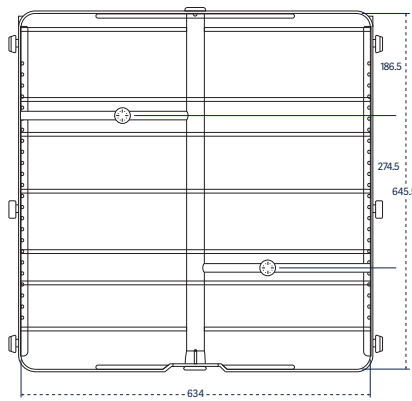

Catalog No. 2 IXL 16

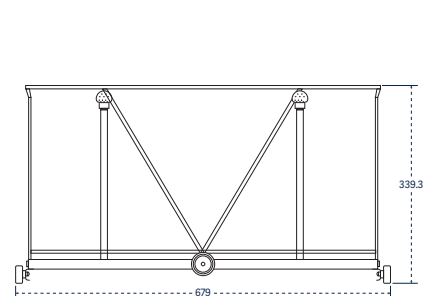
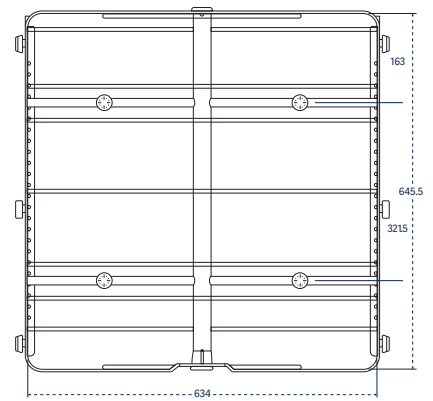

Catalog No. 4 IXL 16

Combination short/long injectors

For inside out cleaning of mixed loads of narrow neck glassware, bottles, cylinders, boiling flasks, Erlenmeyer flasks and volumetric flasks.

1600 LXP

Parts number

36 short and long jets, 6 mm diameter

36 IXLC 16

02600099

64 short and long jets, 6 mm diameter

64 IXLC 16

02600102

80 short and long jets, 6 mm diameter

80 IXLC 16

02600105

100 short and long jets, 6 mm diameter

100 IXLC 16

02600092

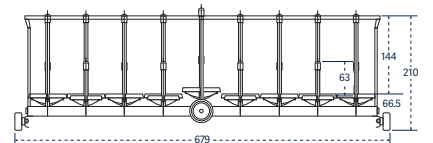
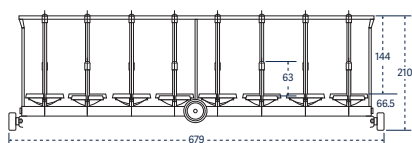
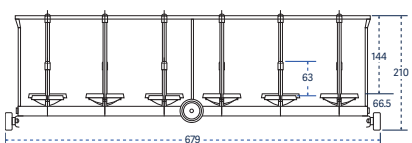
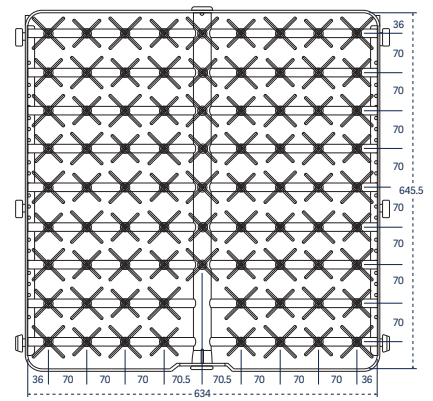
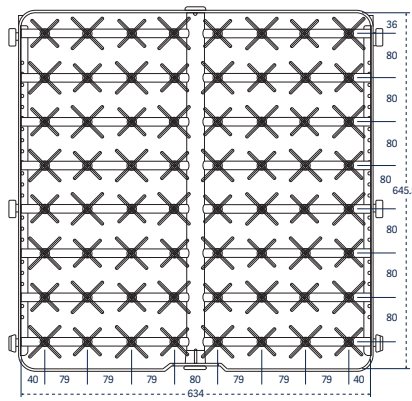
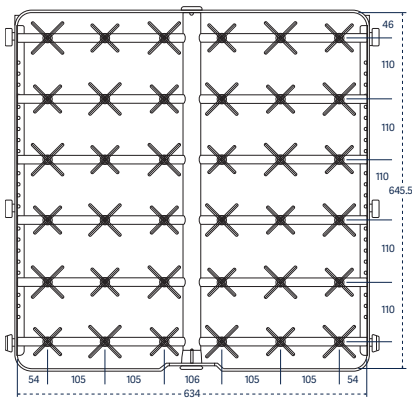

Catalog No. 36 IXLC 16

Catalog No. 64 IXLC 16

Catalog No. 80 IXLC 16

Pipette racks	1600 LXP	Part number
Accessory pipette racks are configured to accommodate reusable pipettes.		
Grommet style, individually loaded, 105 position	105 PIP 14	02600106
Bioreactor rack	1600 LXP	Part number
Rack for 1-3 L Bioreactors	BRWR 16	AA02600115
Storage stand	1600 LXP	Part number
An accessory storage stand offers a convenient place to store accessory racks and baskets when not in use.		
Holds up to 5 racks	RP 16	01040063

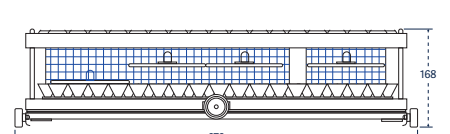
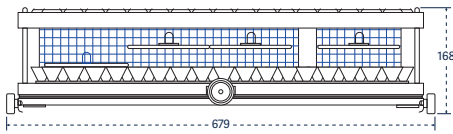
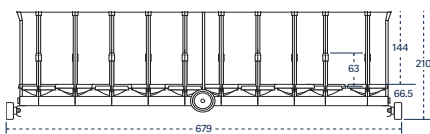
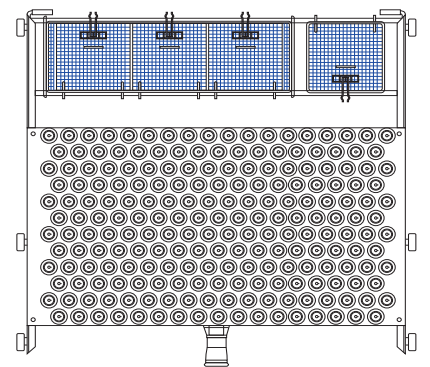
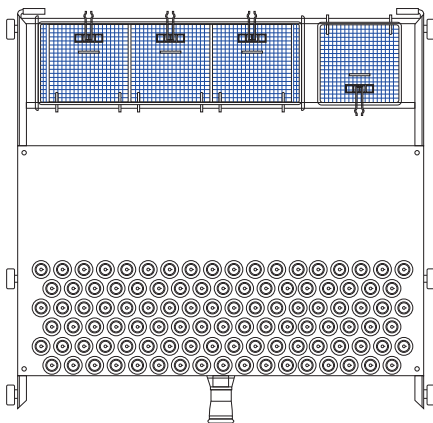
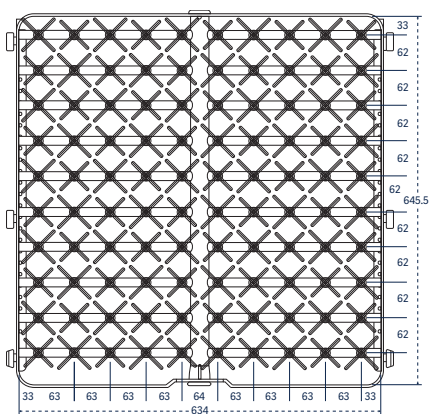

Catalog No. 100 IXLC 16

Catalog No. 105 PIP 16

Catalog No. 210 PIP 16

Injector KIT packages

KIT enable customization of standard injector racks to fit specific needs. Each KIT include 10 complete injectors with their supports and nozzles.

Part number

Long injectors, length of 230 mm and 6 mm diameter	6007500984
Long injectors, length of 171 mm and 6 mm in diameter	6007500890
Short injectors, length of 86 mm and 6 mm in diameter	6007500957
Short injectors, length of 56 mm and 6 mm in diameter	6007501012
Long injectors, length of 171 mm and 8 mm in diameter	6007501011
Needle injectors, length of 86 mm	6007501007

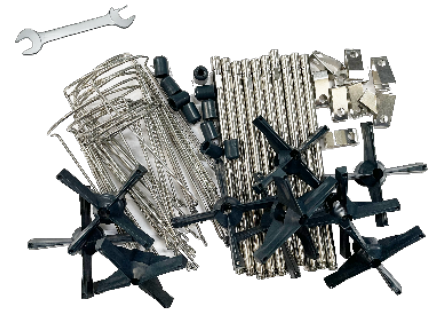

Trolley

The stainless steel loading trolley transfers the load and mates with the washer to simplify loading and unloading. The trolley includes a retainer lip to keep the floor dry from residual water. Includes locking casters.

1600 LXP

Part number

Trolley, 4 levels

TN 16

02530020

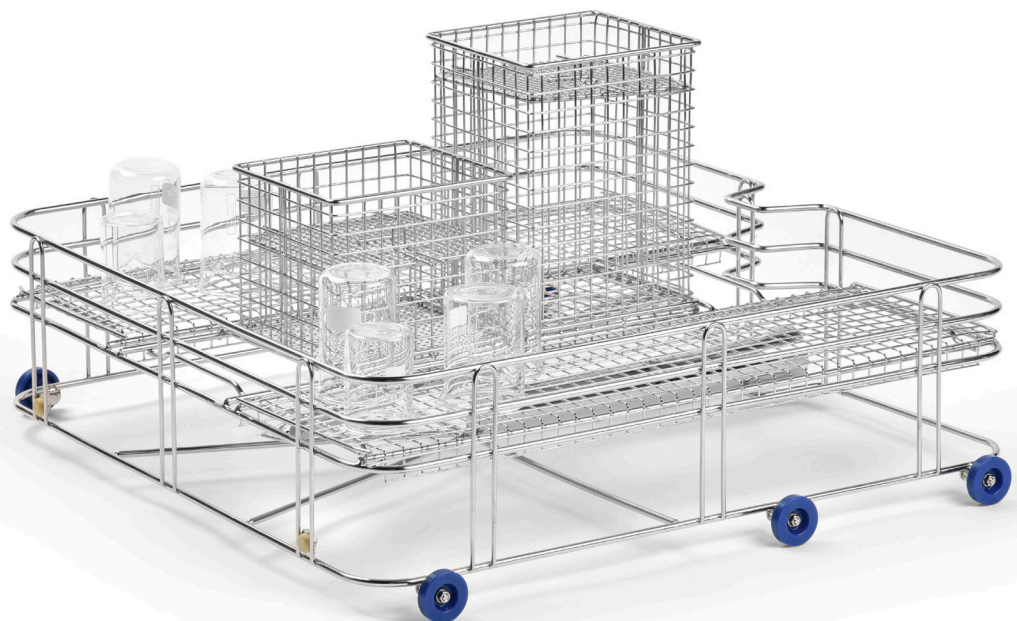



WolfLabs

Pricing on any accessories shown can be found by keying the part number into the search box on our website.

The specifications listed in this brochure are subject to change by the manufacturer and therefore cannot be guaranteed to be correct. If there are aspects of the specification that must be guaranteed, please provide these to our sales team so that details can be confirmed.

www.wolflabs.co.uk

Tel : 01759 301142

Fax : 01759 301143

sales@wolflabs.co.uk

Please contact us if this literature doesn't answer all your questions.