



KERN & Sohn GmbH

Ziegelei 1
D-72336 Balingen
E-Mail: info@kern-sohn.com

Phone: +49-[0]7433- 9933-0
Fax: +49-[0]7433-9933-149
Internet: www.kern-sohn.com

Operating instructions Precision balance

KERN PWS

Version 1.0
2022-08
GB



TPWS-BA-e-2210



KERN PWS

Version 1.0 2022-08

Operating instructions Precision balance

Contents

1	Technical data	4
2	Declaration of conformity	5
3	Appliance overview	6
3.1	Components	6
3.2	Keyboard	8
3.3	Display	9
4	Basic Information (General)	10
4.1	Proper use	10
4.2	Improper Use	10
4.3	Warranty	10
4.4	Monitoring of Test Resources	10
5	Basic Safety Precautions	11
5.1	Pay attention to the instructions in the Operation Manual	11
5.2	Personnel training	11
6	Transport and storage	11
6.1	Testing upon acceptance	11
6.2	Packaging / return transport	11
7	Unpacking, Installation and Commissioning	12
7.1	Installation Site, Location of Use	12
7.2	Unpacking, Scope of delivery	12
7.3	Placing	14
7.4	Levelling	15
7.5	Mains connection	15
7.5.1	Turning On the Power	16
7.6	Initial Commissioning	16
7.7	Connection of peripheral devices	16
8	Menu	17
8.1	Menu overview	17
8.2	Navigation in the menu	18
9	Basic Operation	19
9.1	Turn on/off	19
9.2	Zeroing	20
9.3	Taring	20
9.4	Selection of a weighing application	21
9.5	Simple weighing	22
9.6	Numeric entry	22
10	Piece counting	24
11	Percent weighing	27
12	Coefficient multiplication	30
13	Density determination	32
13.1	Density Table for Liquids	36
13.2	Data output of the specific density to a printer	37

14	Animal weighing	38
14.1	Additional settings	38
14.1.1	Auto Tare.....	39
14.1.2	Data output.....	39
14.1.3	Set weight range	39
14.1.4	Set the balance's response.....	39
15	Weighing with tolerance range	40
15.1	Selection of weighing function with tolerance range	41
15.2	Set discrimination condition	41
15.3	Setting the discrimination range	41
15.4	Set the number of tolerance limits	41
15.5	Set discrimination method	42
15.6	Set acoustic signal	42
15.7	Setting the tolerance values	42
15.7.1	Absolute values.....	42
15.7.2	Differential values.....	45
15.8	Setting the display to present results	49
16	Totalization	50
16.1	Select the Totalizing function	50
16.2	Using the totalizing function	51
16.2.1	TOTAL-Adding	51
16.2.2	NET-Adding.....	51
16.3	Show or clear the total sum	52
17	Settings for operation and operating behaviour	53
17.1	Setting the weighing units	53
17.2	Bar graph display	54
17.3	Acoustic signal	54
17.3.1	Activate / deactivate the acoustic signal	54
17.3.2	Adjusting the sound level of the acoustic signal	54
17.4	Background lighting	54
17.4.1	Turn off of the background lighting automatically	55
17.4.2	Checking the background lighting	55
17.5	Stability settings	55
17.5.1	Sensitivity	55
17.5.2	Stabilisation waiting time.....	55
17.6	Reaction settings	56
17.7	Zero-Tracking	56
17.8	Automatic switch-on function	56
18	System Settings	57
18.1	Balance identification number	57
18.2	Readability	58
18.2.1	Readabilities for PWS 800-2	59
18.2.2	Readabilities for PWS 3000-1 and PWS 8000-1	59
18.3	Restore last tare value	60
18.4	Restore factory settings	60
19	Adjustment	61
19.1	Adjustment	61
19.2	Adjustment test	62
20	Interfaces	64
20.1	RS-232C interface for data input and output	64
20.1.1	Technical data	64
20.1.2	Interface cable.....	65
20.2	Data output formats	65
20.2.1	Data composition	65
20.2.2	Data description	65
20.3	Data input	67
20.3.1	Input format	67
20.4	Response formats	69

20.4.1	A00/Exx Format	69
20.4.2	ACK/NAK Format	70
20.5	Communication settings.....	70
20.5.1	Enable / disable interface and data format	70
20.5.2	Change communication settings	70
20.6	Printer functions.....	72
20.6.1	Output of the adjustment test result	73
20.6.2	Output of measurements obtained.....	73
20.6.3	Output language.....	73
21	Servicing, maintenance, disposal	74
21.1	Cleaning	74
21.2	Servicing, maintenance	74
21.3	Disposal.....	74
22	Instant help for troubleshooting.....	75
22.1	Error messages	76

1 Technical data

KERN	PWS 3000-1	PWS 8000-1	PWS 800-2
Item no./ Type	TPWS 3200-1-A	TPWS 8200-1-A	TPWS 820-2-A
Readability (d)	0.1 g	0.1 g	0.01 g
Weighing range (max)	3.2 kg	8.2 kg	820 g
Reproducibility	0.1 g	0.1 g	0.01 g
Linearity	0.1 g	0.1 g	0.01 g
Stabilization time	3 s		
Recommended adjustment weight, not added (Category)	3 kg (F1)	2 kg (F1); 5 kg (F1)	200 g (F1); 500 g (F1)
Warm-up time	2 h		
Weighing Units	g, kg, ct, oz, lb, ozt, dwt, gn, tl (Hong Kong), tl (Singapore, Malaysia), tl (Taiwan), mom, to		
Smallest part weight during piece counting	100 mg (under lab conditions*)	100 mg (under lab conditions*)	10 mg (under lab conditions*)
	1 g (under normal conditions**)	1 g (under normal conditions**)	100 mg (under normal conditions**)
Reference piece quantities at piece count	5, 10, 30, 100		
Weighing plate, stainless steel	190 x 190 mm	190 x 190 mm	∅ 140 mm
Dimensions of the housing (B x D x H) [mm]	310 x 208 x 87		
Net weight (kg)	1.52 kg		
Permissible ambient condition	10 °C to + 30 °C		
Humidity of air	80 %		
Power supply unit input voltage	AC 100-240 V, 300 mA 50/60Hz		
Balance input voltage	DC 5.95 V, 1.0 A		
Interfaces	RS-232		
Degree of pollution	2		
Overvoltage category	2		
Metres in height	Up to 2000 m		
Place of installation	In sealed rooms only		

*** Smallest component weight for part counting - under lab conditions:**

- There are ideal ambient conditions for high-resolution counting
- The parts to be counted are not scattered

**** Smallest component part for part counting – under normal conditions:**

- There are unsteady ambient conditions (draft, vibrations)
- The parts to be counted are being scattered

2 Declaration of conformity

The current EC/EU Conformity declaration can be found online in:

www.kern-sohn.com/ce

i For verified weighing scales (= weighing scales assessed for conformity) the declaration of conformity is included in the scope of delivery.

3 Appliance overview

3.1 Components

PWS 3000-1 and PWS 8000-1:

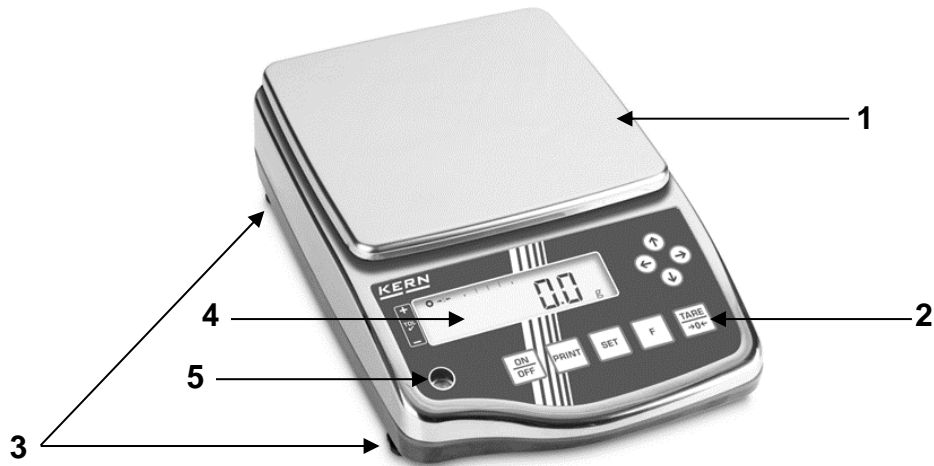

PWS 800-2:



Pos.	Designation
1	Weighing plate
2	Keyboard
3	Footscrews
4	Display
5	Bubble level

Rear view (weighing plate on the picture: PWS 3000-1 and PWS 8000-1):

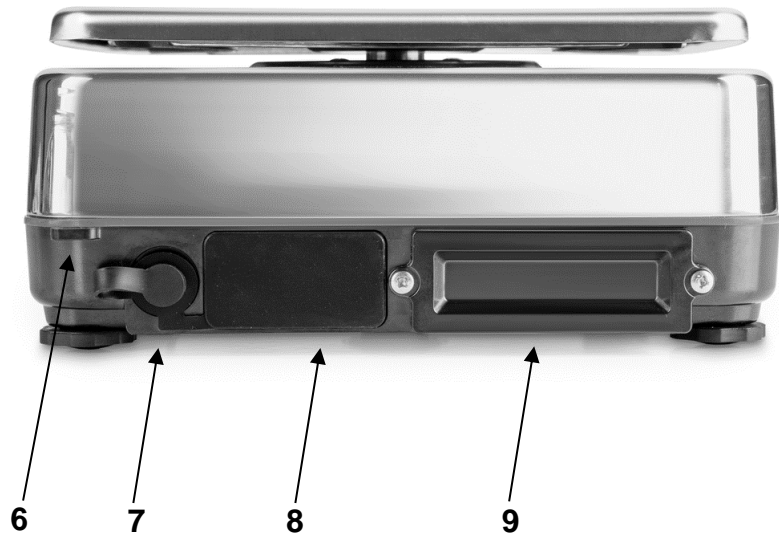

Pos.	Designation
6	Attachment eyelet for anti-theft device
7	Power plug with protective cap
8	RS-232C interface with protective cap
9	Battery compartment (rechargeable battery is available as an optional accessory)



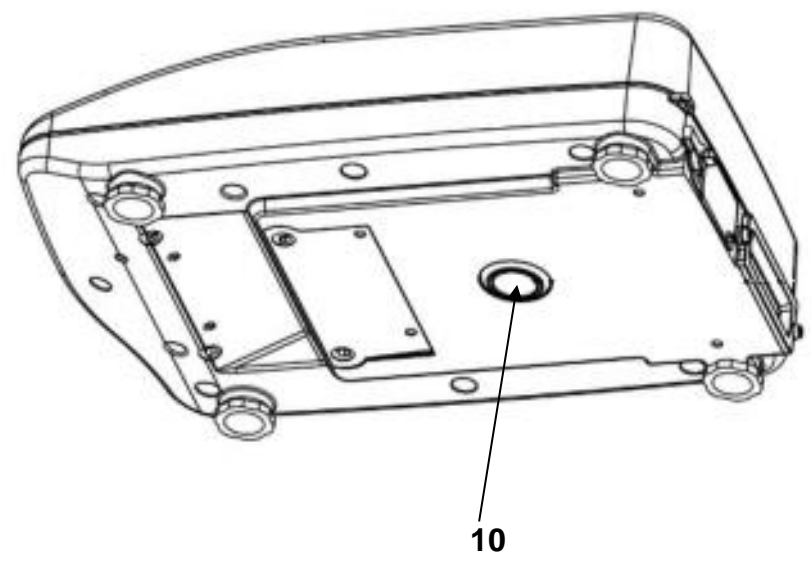



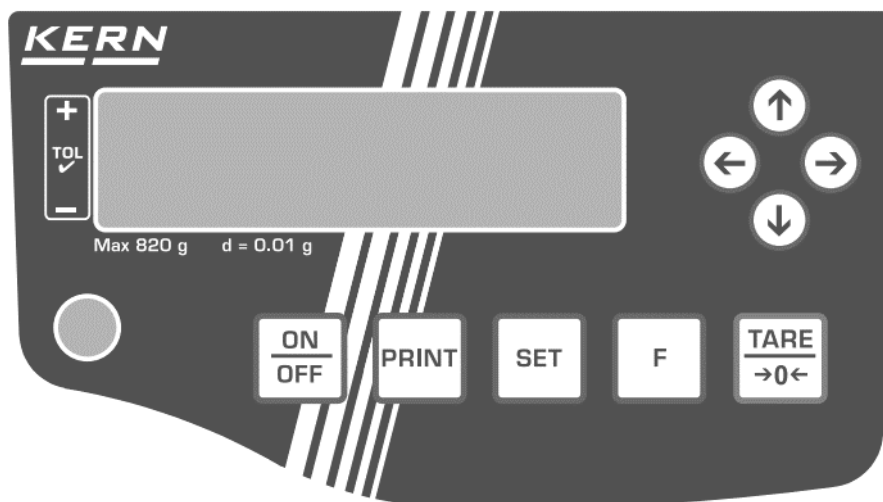

View from below:



Pos.	Designation
10	Cover hook for underfloor weighing

3.2 Keyboard



Button	Designation	Description
	[ON/OFF]	Switch-on Switching Off
	[PRINT]	Data export to external device Cancel setting
	[SET]	Accept setting
	[F]	Open menu (keep key pressed for about 2 seconds) Change display Confirm entry
	[TARE/ZERO]	Taring and zeroing
	[↑]	Setting selection upwards Increase numerical input by 1
	[↓]	Select setting downwards Lower numerical input by 1
	[→]	Forward to next menu level Select character position
	[←]	Menu level back Select character position

3.3 Display

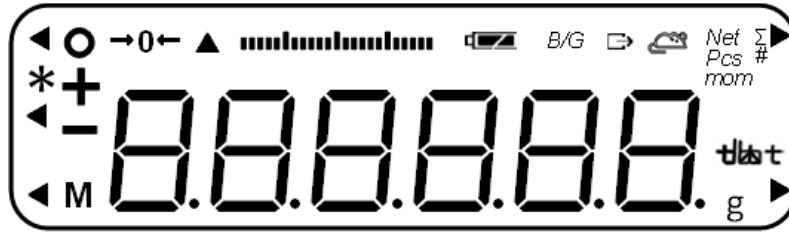

No.	Display	Designation	Description
1		Stability display	Is displayed when the weight value is stable
2		"Tolerance range weighing" indicator	Indicates the tolerance range within which the weighing result lies.
3		"Animal weighing" indicator	Indicates the reaction speed of the balance when weighing animals.
4		Asterisk	Indicates that weight value can be added
5		Minus	Displays negative values
6		Indicator "Process"	Indicates that the balance is processing data
7		Indicator "zero display"	Displays zero position
8		Bar graph display	Indicates how much the weighing plate is loaded with respect to the maximum weighing range Indicates the tolerance range of the weighing result
9		Charge status display	Displayed during battery operation
10		Display gross weight value	Displays gross weight
11		Indicator „Data output“	Displayed when balance is sending data to external device
12		"Animal weighing" indicator	Shown when the balance is in animal weighing mode
13		Display net weight value	Shown when the tare weight has been subtracted
14		"Total" indicator	Shown when the total sum is displayed
15		"Piece counting" indicator	Shown when piece counting has been activated
16		"Coefficient multiplication" indicator	Shown when coefficient multiplication has been activated.
17		„Percent Weighing“ Indicator	This is displayed when the percent weighing function has been activated.
18		"ID number" indicator	Lights up when ID is displayed or entered.
19		Gram	Shows unit „Gram“
20		Kilogram	Shows unit „Kilogram“
21		Momme	Indicates "Momme" unit
22		Indicator for different weighing units	Indicates different weighing units in different functions

4 Basic Information (General)

4.1 Proper use

The balance you purchased is intended to determine the weighing value of material to be weighed. It is intended to be used as a “non-automatic balance”, i.e. the material to be weighed is manually and carefully placed in the center of the weighing pan. The weighing result can be read off once a stable weight value has been reached.

4.2 Improper Use

- Our balances are non-automatic balances and not provided for use in dynamic weighing processes. However, the balances can also be used for dynamic weighing processes after verifying their individual operative range, and here especially the accuracy requirements of the application.
- Do not leave permanent load on the weighing pan. This may damage the measuring system.
- Impacts and overloading exceeding the stated maximum load (max) of the balance, minus a possibly existing tare load, must be strictly avoided. Balance may be damaged by this.
- Never operate the balance in explosive environment. The serial version is not explosion protected.
- The structure of the balance may not be modified. This may lead to incorrect weighing results, safety-related faults and destruction of the balance.
- The balance may only be used according to the described conditions. Other areas of use must be released by KERN in writing.

4.3 Warranty

The warranty becomes void if:

- Our conditions in the operation manual are ignored
- The appliance is used beyond the described uses
- The appliance is modified or opened
- Mechanical damage or damage by media, liquids, natural wear and tear
- The appliance is improperly set up or incorrectly electrically connected
- The measuring system is overloaded

4.4 Monitoring of Test Resources

In the framework of quality assurance the measuring-related properties of the balance and, if applicable, the testing weight, must be checked regularly. The responsible user must define a suitable interval as well as type and scope of this test. Information regarding the test equipment monitoring of balances as well as the test weights required for this is available on the KERN homepage (www.kern-sohn.com). In KERN's accredited DKD calibration laboratory test weights and balances may be calibrated (return to the national standard) fast and at moderate cost.

5 Basic Safety Precautions

5.1 Pay attention to the instructions in the Operation Manual



- ⇒ Carefully read this operation manual before setup and commissioning, even if you are already familiar with KERN balances.

5.2 Personnel training

The appliance may only be operated and maintained by trained staff.

6 Transport and storage

6.1 Testing upon acceptance

When receiving the appliance, please check packaging immediately, and the appliance itself when unpacking for possible visible damage.

6.2 Packaging / return transport



- ⇒ Keep all parts of the original packaging for a possibly required return.
- ⇒ Only use original packaging for returning.
- ⇒ Prior to dispatch disconnect all cables and remove loose/mobile parts.
- ⇒ Reattach possibly supplied transport securing devices.
- ⇒ Secure all parts such as the glass wind screen, the weighing plate, power unit etc. against shifting and damage.

7 Unpacking, Installation and Commissioning

7.1 Installation Site, Location of Use

The balances are designed in a way that reliable weighing results are achieved in common conditions of use.

You will work accurately and fast, if you select the right location for your balance.









On the installation site observe the following:

- Place the balance on a firm, level surface.
- Avoid extreme heat as well as temperature fluctuation caused by installing next to a radiator or in the direct sunlight.
- Protect the balance against direct draughts due to open windows and doors.
- Avoid jarring during weighing.
- Protect the balance against high humidity, vapours and dust.
- Do not expose the device to extreme dampness for longer periods of time. Non-permitted condensation (condensation of air humidity on the appliance) may occur if a cold appliance is taken to a considerably warmer environment. In this case, acclimatize the disconnected appliance for ca. 2 hours at room temperature.
- Avoid static charge of goods to be weighed or weighing container.
- Do not operate in areas with hazard of explosive material or in potentially explosive atmospheres due to materials such as gasses, steams, mists or dusts.
- Keep away chemicals (such as liquids or gasses), which could attack and damage the balance inside or from outside.
- Keep IP protection of the device.
- If any electromagnetic fields occur, static charges (for example when weighing / counting plastic parts) as well as unstable power supply, large display deviations (incorrect weighing results, as well as damage to the balance) are possible. In that case, the location must be changed.

7.2 Unpacking, Scope of delivery

Remove device and accessories from packaging, remove packaging material and install the device at the planned work place. Check if that there has been no damage and that all items of delivery scope are present.

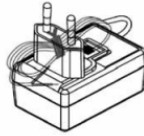
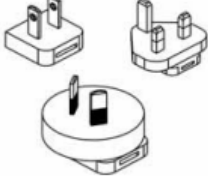
Scope of delivery:

1. Balance	
2. Weighing plate (for PWS 3000-1 and PWS 8000-1)	
3. Weighing plate (for PWS 800-2)	
4. Weighing plate support (for PWS 3000-1 and PWS 8000-1)	
5. Weighing plate support (for PWS 800-2)	
6. Screw for weighing plate support	
7. Mains adapter	
8. Power plug set	
9. Operating instructions	

7.3 Placing



The correct location of high-resolution precision balances is crucial for the accuracy of the weighing results (see chapter 7.1).



The IP protection of the balance is only maintained if

- the weighing plate is attached
- the hole on the underside is covered with the appropriate cover

1. Place the weighing plate carrier with the holes over the pins on the balance.
2. Fix the weighing plate with the screw

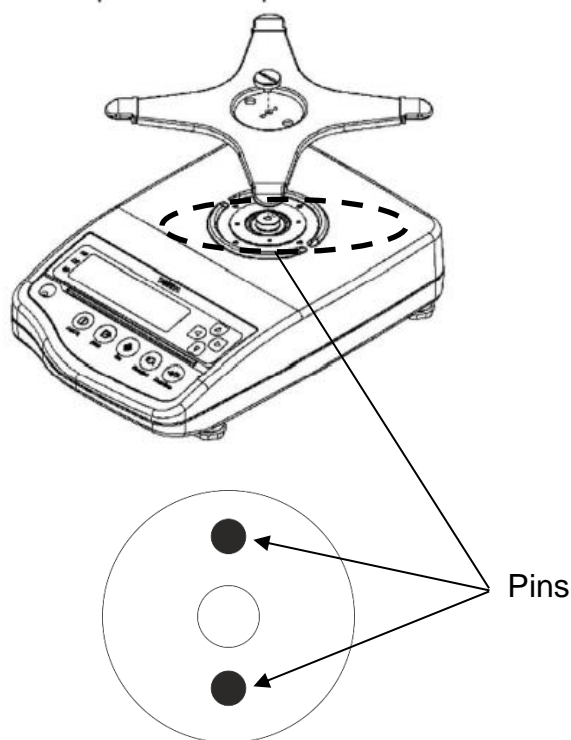

2. Place the weighing plate on the weighing plate carrier

PWS 3000-1 and PWS 8000-1:

PWS 800-2:



3. Connect the power supply unit (Installation of the power supply unit: see chap.7.5)

7.4 Levelling

1. Level balance with foot screws until the air bubble of the water balance is in the prescribed circle

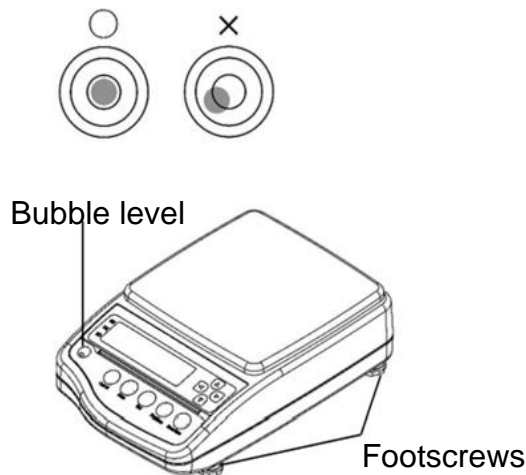

⇒ Check levelling regularly

7.5 Mains connection



Select a country-specific power plug and insert it in the mains adapter.



Check, whether the voltage acceptance on the balance is set correctly. Do not connect the balance to the power mains unless the information on the balance (sticker) matches the local mains voltage.

Only use KERN original mains adapter. Using other makes requires consent by KERN.



Important:

- Before starting your weighing balance, check the mains cable for damage.
- Make sure that the power supply unit and the power plug do not come into contact with liquids. Cover the power connector with the protective cap provided whenever the balance is disconnected from the electricity supply.
- Ensure access to mains plug at all times.

Installation of the power supply unit:

1. Place the country-specific power plug at a slight angle in the recess of the power supply unit so that the spring points in the direction of the locking arrow of the power supply unit.
2. Push the locking mechanism of the power plug downwards and press the power plug into the recess of the power supply unit. Then release the lock (make sure that the power plug is engaged).

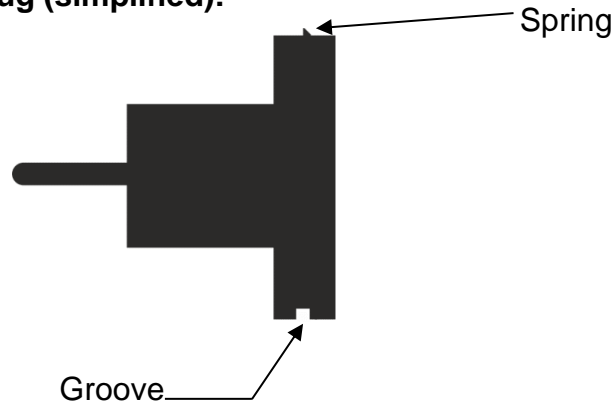

Side view of the power plug (simplified):

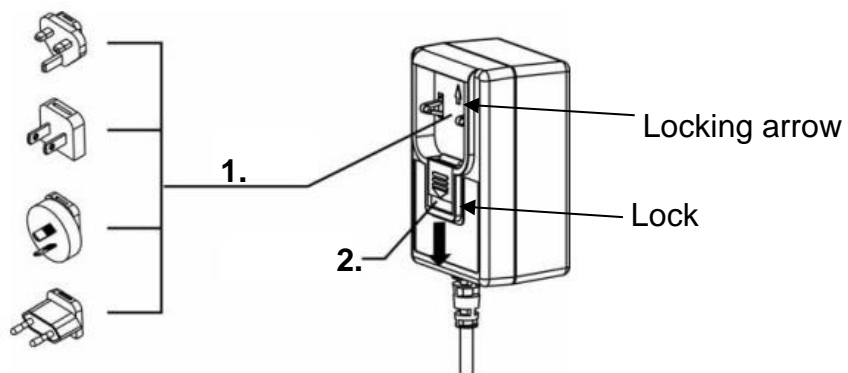

Inserting the power plug into the power supply unit



7.5.1 Turning On the Power

	⇒ Connect the balance to the power supply
	⇒ Turn on the balance by pressing the [ON/OFF] key.

7.6 Initial Commissioning

The balances must have reached their operating temperature for accurate weighing results to be obtained from the electronic balances (see Warm-up Time, Chapter 1). During this warming up time the balance must be connected to the power supply (mains, accumulator or battery). The accuracy of the balance depends on the local acceleration of gravity. It is essential that the instructions in the chapter on Adjustment are followed (see chap.19).

7.7 Connection of peripheral devices

Before connecting or disconnecting of additional devices (printer, PC) to the data interface, always disconnect the balance from the power supply.

Make sure that the connections of the RS-232C interface and the connection for peripheral devices do not come into contact with liquids. Cover the connectors on the machine with the protective caps provided when not in use.

With your balance, only use accessories and peripheral devices by KERN, as they are ideally tuned to your balance.

8 Menu

Settings on the balance can be changed from the menu by pressing the **[F]** key.



- To open the menu, the balance must be in the gram display (switch-over the display: Press **[F]** key).
- For navigation in the menu see chapter 8.2









8.1 Menu overview

The balance's menu consists of several levels. The first level consists of the main menus. Depending on the setting, you get access to further menu levels.

You will find a summary of the setting options in the individual chapters.

First menu level	Settings	Chapter
1.SEt	Selection of a weighing application	9.4
2.SEL	Weighing with tolerance range	15
	Totalization	16
3.A.0	Zero-Tracking	17.7
4.S.d.	Stability settings: Sensitivity	17.5.1
5.r.E.	Reaction settings	17.6
6. I.F.	Communication settings	20.5
7.CA.	Adjustment functions	19
8.b.G.	Bar graph display	0
9.A.P.	Automatic switch-on function	17.8
A.A.b.	Turn off of the backlight automatically	17.4.1
b 1.u.A	Weighing unity A	17.1
b2.d.A	Readability unit A	18.2
b3.u.b	Weighing unit B	17.1
b4.d.b	Readability unit B	18.2
E.G.LP	Printer functions	20.6
H.tA.	Stabilisation waiting time	17.5.2
J.tA.0	Restore last tare value	18.3
n.b2.	Acoustic signal settings	17.3
o.b.L.	Checking the backlight	17.4.2

8.2 Navigation in the menu

Button	Designation	Description
	[F]	Open menu (press and hold for about 2 seconds) Following menu level (press briefly)
	[PRINT]	Close menu Cancel input
	[←]	Forward to next menu level
	[→]	Menu level back
	[↑]	Setting selection upwards
	[↓]	Select setting downwards
	[TARE/ZERO]	Switch through setting selection
	[SET]	Storing settings

Open menu:



⇒ Press and hold the [F] key for about 2 seconds.



⇒ Display changes to <Func>.

⇒ Release [F] key



If you continue to hold down the [F] key after <Func> is displayed, the balance will switch to another mode. In this situation you can press the [PRINT] key to cancel the action.

9 Basic Operation

9.1 Turn on/off



After switching on, the balance always starts with the last weighing application that was used before switching off.

Start-up:

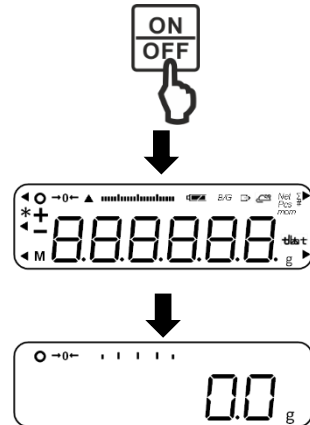

- ⇒ Press **[ON/OFF]** key
- ⇒ The display lights up
- ⇒ Wait until the weight display appears
- ⇒ The display shows zero
- ⇒ The balance is now ready for weighing

Check the display:

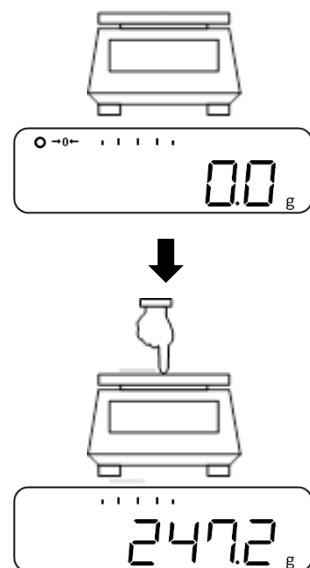

- ⇒ You can check whether the weight value shown on the display changes using light finger pressure on the weighing plate,

Switching off:

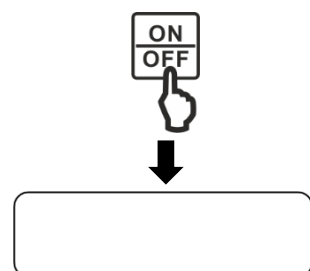

- ⇒ When the balance is switched on, press the **[ON/OFF]** key.
- ⇒ The balance display turns off

9.2 Zeroing



If **<Net>** is shown on the display after pressing the **[TARE/ZERO]** key, taring has been performed instead of zeroing. For more information on taring, see chapter 9.3.

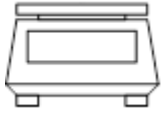

⇒ Unload weighing plate



⇒ Press **[TARE/ZERO]** key



⇒ Balance performs zeroing

⇒ The display shows the value **<0.0 g>** and the zero indication **<->0<->**.

9.3 Taring

The tare weight of any balance container can be tared at the touch of a button, so that the net weight of the weighed goods is displayed during subsequent weighing operations.



If a tare weight is being used, the maximum weighing range for weighing goods is reduced by the value of the tare weight.



⇒ Place the empty weighing container on the weighing plate



⇒ The weight of the weighing container is displayed



⇒ Press **[TARE/ZERO]** key

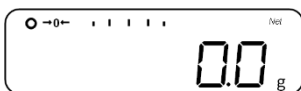

⇒ Balance performs taring

⇒ The display shows the value **<0.0 g>** and the zero display **<Net>**.



⇒ Fill the weighing container with the material being weighed

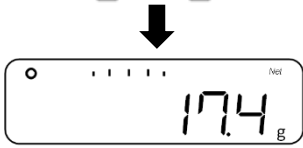

⇒ Read off the net weight of the material to be weighed

- When the balance is unloaded the saved taring value is displayed with negative sign.
- i** • To clear the stored tare value, unload the weighing plate and press the **[TARE/ZERO]** key.
- The taring process can be repeated any number of times. The limit is reached when the whole weighing range is exhausted.

9.4 Selection of a weighing application



To open the menu, the balance must be in the gram display (switch-over the display: Press **[F]** key).



⇒ Press and hold the **[F]** key for about 2 seconds.



⇒ Display changes to **<Func>**.

⇒ Release **[F]** key



⇒ Select the desired weighing application using the **[↑]** and **[↓]** keys (or **[TARE/ZERO]** key).

- | | |
|--------------------|----------------------------|
| 1. SEt „1“. | Simple weighing |
| 1. SEt 2 | Piece counting |
| 1. SEt 3 | Percent weighing |
| 1. SEt 4 | Coefficient multiplication |
| 1. SEt 5 | Density determination |
| 1. SEt 6 | Weighing animals |



⇒ Press the **[SET]** key to confirm the selection.

9.5 Simple weighing



If you use a weighing container, tare before weighing (see chapter 9.3).



⇒ Select weighing application <1. SEt 1> (for selection see chapter 9.4)



⇒ Place the weighed material on the weighing plate or in the weighing container.

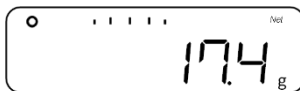

⇒ Read off weighing result

Further displays:

Press the [F] key to switch-over the display on the balance. The display depends on the active weighing application and the additional functions that have been enabled.









Display sequence	Display	Display on balance
1	Net weight value (unit A)	Net
2	Gross weight value (unit A)	B/G
3	Net weight value (unit B)	Net
4	Total weight (unit A)	Σ

9.6 Numeric entry

Tolerance limits, reference weight values, coefficients, temperature values, specific density and the balance identification number can be entered manually on the balance.



- Whether it is permissible to enter a point for weight values depends on the readability of the balance
Example: Readability (d) = 0.1 g → Permissible entry: One decimal place; Inadmissible input: More than one decimal place → Balance rounds up or down
- The balance can display a maximum of six characters

Button	Function
	Cancel input
	Save input and exit
	Enter next character
	Increase character by 1
	Increase character by 1
	Decrease character by 1
	Enter next character
	Select / delete last character

10 Piece counting

The **piece counting** application allows you to count several pieces placed on the weighing plate.

Before the balance can count parts, it must know the average part weight (i.e. reference). Proceed by putting on a certain number of the parts to be counted. The balance determines the total weight and divides it by the number of parts, the so-called reference quantity. Counting is then carried out on the basis of the calculated average piece weight.

As a rule: **The higher the reference quantity the higher the counting exactness.**



- You can cancel the setting of the piece count by pressing the **[PRINT]** key.
- If you are using a weighing container, tare before setting the reference piece count (see chapter 9.3).
- The acoustic signal only sounds if it has been activated (for settings, see chapter 17.3).

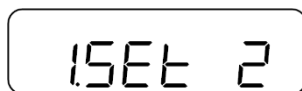

⇒ Select weighing application **<1. SEt 2>** (for selection, see chapter 9.4)

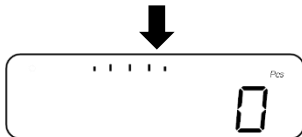

⇒ The display shows **<Pcs>**.



⇒ Press and hold the **[F]** key for about 2 seconds.



⇒ Display changes to **<U. Set>**

⇒ Release **[F]** key



⇒ The reference piece quantity flashes on the display (in this example: **<on 10>**)

⇒ Use the **[↑]** and **[↓]** keys (or **[TARE/ZERO]** key) to select the desired reference quantity.

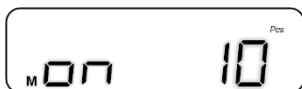

on 5	5 items
on 10	10 items
on 30	30 items
on 100	100 items



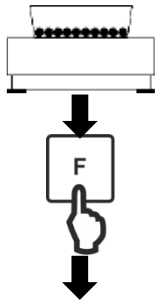

- ⇒ Place the number of pieces according to the entered reference quantity on the weighing plate or in the weighing hopper.
- ⇒ Press the **[F]** key to store the weight value of the reference piece quantity.

Simple SCS (optional; press [F]key to reach to the measuring mode):

- ⇒ Reference piece quantity on the display starts flashing
- ⇒ Place additional reference pieces (the number of pieces must not be more than three times the reference quantity → initially selected). Example: Selected = 10 pieces, Additional reference pieces = 30 items or less).
- ⇒ The stability indicator appears and an acoustic signal sounds (if activated, see chapter . 17.3.1), when the weight value of the reference pieces has been stored.
- ⇒ Press the **[F]** key to finish weighing the reference quantity.

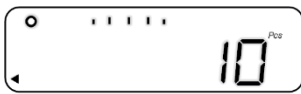

- ⇒ An acoustic signal sounds and **<End.>** is displayed.

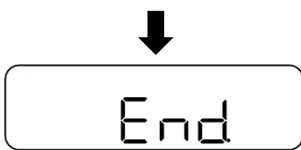

- ⇒ The display changes to the piece counting mode



- ⇒ Place more weighing goods on the weighing plate or in the weighing hopper.



- ⇒ Read off the piece quantity

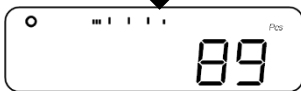

When the balance displays <Add>, <Sub> or <L-Err>:



- **<Add>**: Number of additional samples is too small. Add more samples.
- **<Sub>**: Number of extra samples is too large. Decrease the sample.
- **<L-Err>**: Average piece weight is smaller than the smallest piece weight.

Further displays:

Press the **[F]** key to switch the display on the balance. The display depends on the active weighing application and the additional functions that have been enabled.

Display sequence	Display	Display on balance
1	Quantity of pieces (Pcs)	Net
2	Total quantity of pieces (Pcs)	Σ
3	Average piece weight (unit A)	Pcs
4	Net weight value (unit A)	Net

11 Percent weighing

The application **Percent Weighing** lets you to check the weight of a sample as a percentage, referred to a reference weight.

i	<ul style="list-style-type: none"> If you are using a weighing container, tare before setting the reference piece count (see chapter 9.3). The readability of the balance automatically adjusts to the reference weight: 	
	Readability in %	Weight range of the reference weight
	1 0.1 0.01	Minimum load \leq Reference weight $<$ Minimum load x 10 Minimum load x 10 \leq Reference weight $<$ Minimum load x 100 Minimum load x 100 \leq Reference weight
Model	Minimum load for percentage weighing	
PWS 800-2	1 g	
PWS 3000-1 and PWS 8000-1:	10 g	

The reference weight can be recorded in two ways:

- Actual value setting method: Weighing the **reference** weight
- Numeric entry of the reference weight

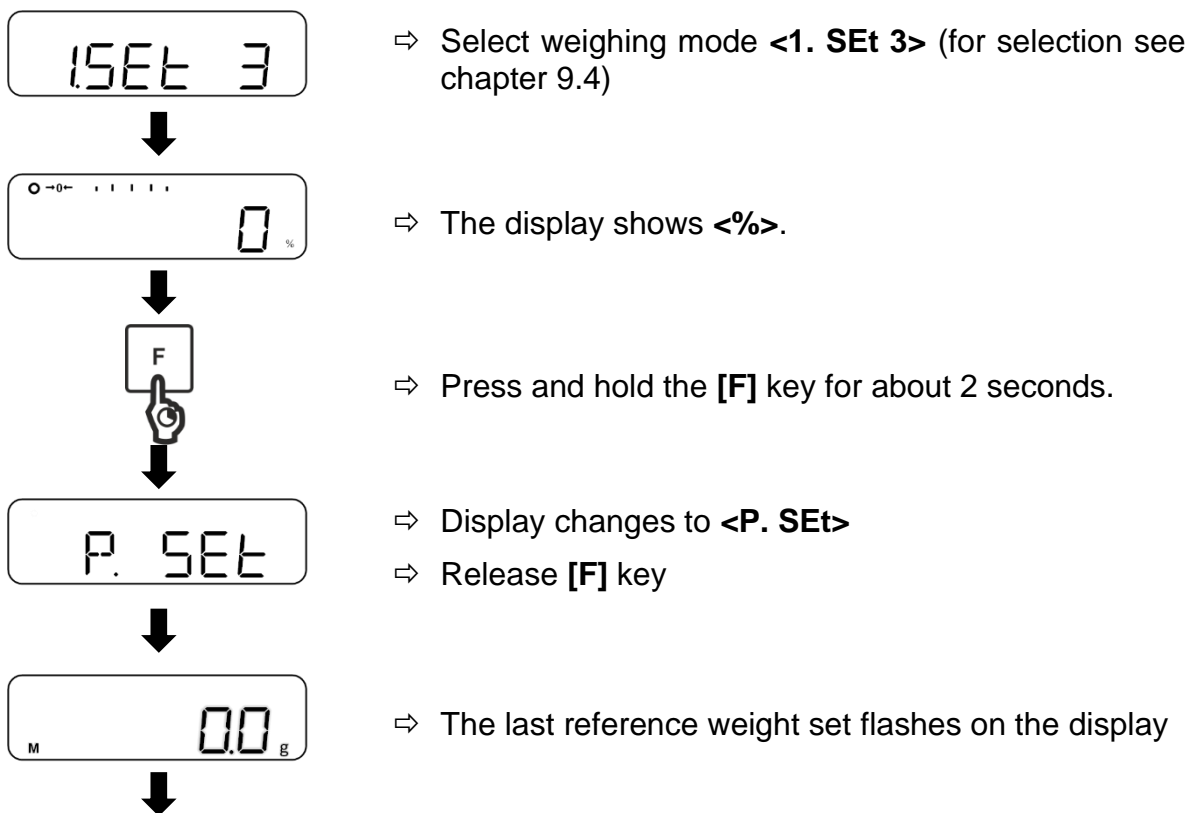

Actual value setting method:

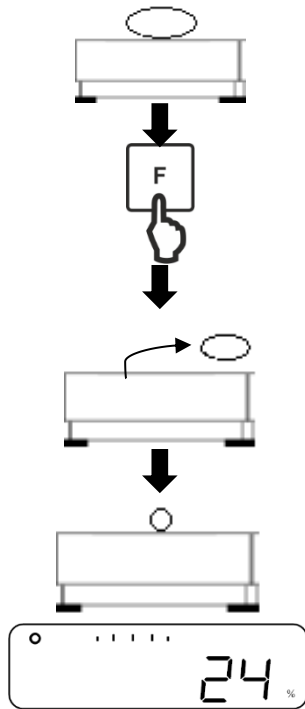

⇒ Place the reference weight on the weighing plate or in the weighing hopper.

⇒ Press **[F]** key

⇒ Remove reference weight

⇒ Place the samples on the weighing plate or in the weighing container and read off the percentage value.

Numerical input of reference weight:

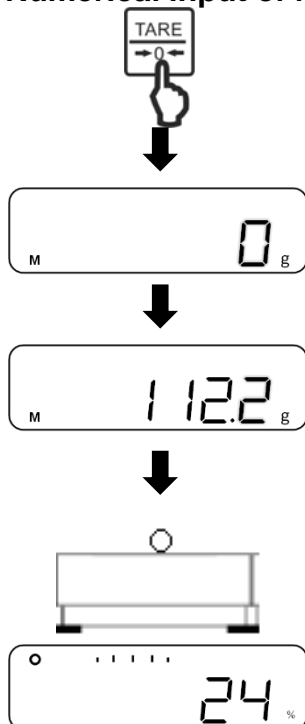

⇒ Press **[TARE/ZERO]** key

⇒ **<0 g>** flashes on the display

⇒ Enter reference weight (numeric entry: see chapter 9.6)

⇒ Place goods onto weighing plate

⇒ Percentage based on the reference weight is displayed

Further displays:

Press the **[F]** key to switch the display on the balance. The display depends on the active weighing application and the additional functions that have been enabled.

Display sequence	Display	Display on balance
1	Percentage (%)	Net
2	Total percentage (%)	Σ
3	Net weight value (unit A)	Net

12 Coefficient multiplication

The **Coefficient multiplication** application allows you to multiply the weight of a sample by a preset value. The result is shown on the display.



The readability of the balance depends on the coefficient entered



⇒ Select weighing mode **<1.SET 4>** (for selection see chapter 9.4)



⇒ Display shows **<#>**



⇒ Press and hold the **[F]** key for about 2 seconds.

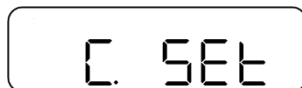

⇒ Display changes to **<C. SEt>**

⇒ Release **[F]** key



⇒ The last coefficient set flashes on the display.



⇒ Press **[TARE/ZERO]** key



⇒ Enter coefficients (Numerical input: see chapter 9.6)



⇒ Press the **[SET]** key to save coefficients.



⇒ Place sample on the weighing plate



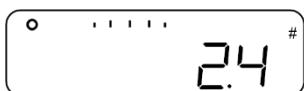

⇒ Weight value is multiplied by the coefficient and result is shown on the display

Further displays:

Press the [F] key to switch the display on the balance. In addition, a number of other functions can be activated depending on the weighing application.

Display sequence	Display	Display on balance
1	Multiplied value (#)	Net
2	Total value (#)	Σ
3	Net weight value (unit A)	Net

13 Density determination

When measuring the density of solids, the solid is first weighed in air and then in an auxiliary liquid whose density is known. From the weight difference results the buoyancy from where the software calculates the density. Distilled water or ethanol are usually used as auxiliary liquids, density tables (for selection see chapter 13.1).

The following steps must be followed to measure the density:

1. Prepare measuring equipment
2. Select weighing application for measuring density
3. Select medium
4. Set water temperature or specific density
5. Weigh sample by underfloor weighing
6. Correction of residual errors due to immersion basket
7. Measure sample



- The hook for underfloor weighing is available as an optional accessory
- Information on this can be found on our homepage:
www.kern-sohn.com



- After completing the underfloor weighing the opening on the bottom of the balance must always be closed (dust protection).
- The balance is not IP65 protected during underfloor weighing
- The immersion basket must not come into contact with the container

1. Prepare measuring equipment

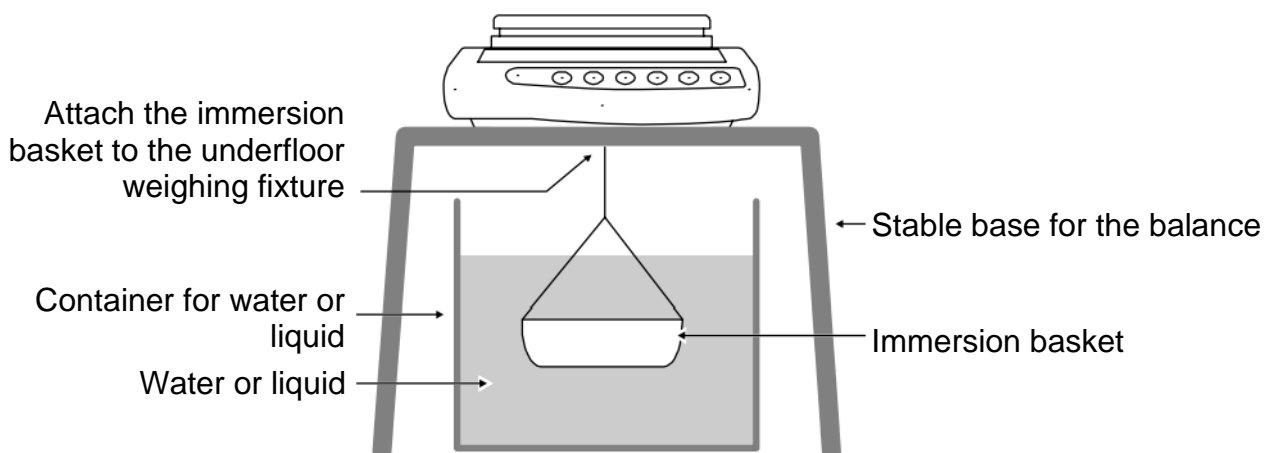

2. Select weighing application for measuring density

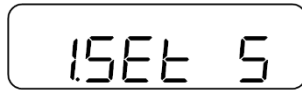

⇒ Select weighing application **<1. SEt 5>** (to select see chapter 9.4)



3. Select medium

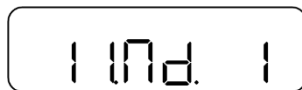

⇒ Navigate to **<11. Md.>** and select medium (Navigation in menu: see chapter 8.2)

- | | | |
|---|--|-------------------------|
| 0 | | Water |
| 1 | | No water (Other medium) |



⇒ Press the **[SET]** key to save the settings

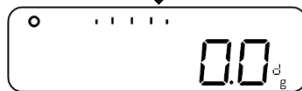

⇒ The display shows **<d>**

4. Set water temperature or specific density



- The water temperature must be between 0 °C and 99.9 °C
- The specific density must be between 0.0001 and 9.999



⇒ Press and hold the **[TARE/ZERO]** key.

When 0 (water) is selected:

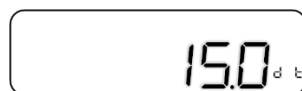

⇒ Display changes to **<d t>** and flashes

⇒ Release the **[TARE/ZERO]** key.



⇒ Press the **[TARE/ZERO]** key to set the water temperature.



⇒ Enter water temperature (numeric entry: see chapter 9.6)



⇒ Press the **[SET]** key to save the entry.

When selecting 1 (No water):



⇒ Display changes to **<d>** and flashes

⇒ Release the **[TARE/ZERO]** key.



⇒ Press the **[TARE/ZERO]** key to set the specific density.



⇒ Enter specific density (Numeric entry: see chapter 9.6)



⇒ Press the **[SET]** key to save the entry.

5. Weigh sample by underfloor weighing

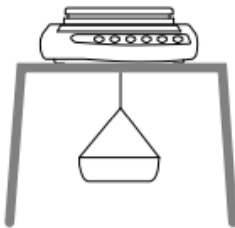

⇒ Attach empty immersion basket to the hook for underfloor weighing.



⇒ Press the **[TARE/ZERO]** key to tare the balance.

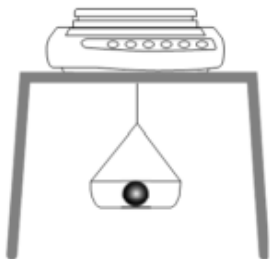

⇒ Place sample in the immersion basket
(In this step the sample can also be placed on the weighing plate)





- ⇒ Press the **[SET]** key when the stable weight value is displayed.



- ⇒ Balance stores weight value and displays <<<>>>.

6. Correction of residual errors due to immersion basket

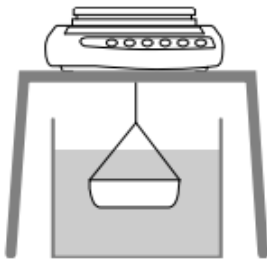

- ⇒ Place container with water or other liquid under the balance
- ⇒ Immerse empty immersion basket in the water or liquid



- ⇒ Press **[TARE/ZERO]** key to tare the balance and correct residual errors of the weighing container

7. Measure sample

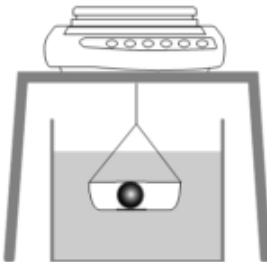

- ⇒ Place sample in the immersion basket
- ⇒ Immerse the immersion basket with sample placed upon completely in the water or liquid.



- ⇒ Press the **[SET]** key when the stable weight value is displayed.

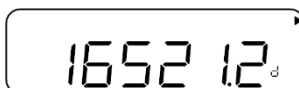

- ⇒ Read off the specific density result



Press the **[SET]** key to return to the weight value display. However, you cannot return to the density display. To do this, you must retake the measurement.

13.1 Density Table for Liquids

Temperature [°C]	Density ρ [g/cm ³]		
	Water	Ethanol	Methanol
10	0.9997	0.7978	0.8009
11	0.9996	0.7969	0.8000
12	0.9995	0.7961	0.7991
13	0.9994	0.7953	0.7982
14	0.9993	0.7944	0.7972
15	0.9991	0.7935	0.7963
16	0.9990	0.7927	0.7954
17	0.9988	0.7918	0.7945
18	0.9986	0.7909	0.7935
19	0.9984	0.7901	0.7926
20	0.9982	0.7893	0.7917
21	0.9980	0.7884	0.7907
22	0.9978	0.7876	0.7898
23	0.9976	0.7867	0.7889
24	0.9973	0.7859	0.7880
25	0.9971	0.7851	0.7870
26	0.9968	0.7842	0.7861
27	0.9965	0.7833	0.7852
28	0.9963	0.7824	0.7842
29	0.9960	0.7816	0.7833
30	0.9957	0.7808	0.7824
31	0.9954	0.7800	0.7814
32	0.9951	0.7791	0.7805
33	0.9947	0.7783	0.7796
34	0.9944	0.7774	0.7786
35	0.9941	0.7766	0.7777

13.2 Data output of the specific density to a printer



- Further settings can only be made after the weighing application Density measurement has been activated (see chap. 13).
- You need a compatible printer to access these functions. Information on this can be found on our homepage:
www.kern-sohn.com

Selecting the data for output:



⇒ In the menu navigate to **<12.do.>** and select setting (Navigation in the menu: see chapter 8.2)

- | | |
|---|--|
| 0 | Show only measured density and weight value |
| 1 | Show all data (Measured density, Weight value, Current water temperature / Specific density) |

Activate / deactivate automatic printout:



⇒ Navigate to **<13.Ao.>** in the menu and select setting (Navigate in the menu: see chapter 8.2)

- | | |
|---|-------------------------------|
| 0 | Automatic display deactivated |
| 1 | Automatic display activated |

14 Animal weighing

The **Animal Weighing** application allows you to measure animals or samples that move whilst being measured. If the weight fluctuations are within a set weight range, the weight value is "frozen" and shown on the display.



- If you use a weighing container, tare before weighing (see chapter 9.3).
- The weight value cannot be "frozen" if the animal moves too much,
- For this function only the weighing unit gram is available
- As the stability detection range is wider in this function, the weighing results may be subject to errors compared to the actual weight values

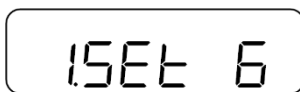

⇒ Select weighing application **<1. SEt 6>** (to select see chapter 9.4)



⇒  is displayed

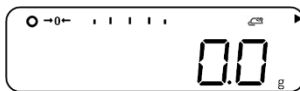

⇒ Press the **[SET]** key to set the reaction of the balance.

- ▶ (top) slow reaction (animal moves a lot)
- ▶ (medium) medium reaction (animal moves a moderate amount)
- ▶ (bottom) fast reaction (animal does not move at all / hardly)



⇒ Place the animal on the weighing plate

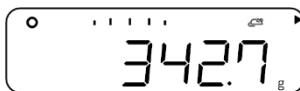

⇒ If the weight fluctuation is within the weight range, the weight value is "frozen" and the balance shows **<h>**

14.1 Additional settings



Additional settings can only be changed after the weighing application Animal weighing has been activated (see chap. 14).

14.1.1 Auto Tare

If Auto Tare has been activated, a tare range is automatically set after the animal has been removed from the weighing plate and the weight fluctuations are within a set range.

If Auto Tare has been deactivated, the value will be "frozen" until the **[TARE/ZERO]** key is pressed.



⇒ In the menu navigate to **<14. At.>** and select setting (navigate in the menu: see chapter 8.2)

- 0 | Disabled
- 1 | Enabled

14.1.2 Data output



⇒ In the menu navigate to **<15. Ho.>** and select setting (Navigate menu: see chapter 8.2)

- 0 | Disabled
- 1 | Enabled (One-time automatic output when value is "frozen").

14.1.3 Set weight range



By changing the readability (d), the stability detection range can also be changed by using a combination of **<16.Wd.>**.



⇒ In the menu navigate to **<16. Wd.>** and select setting (Navigate menu: see chapter 8.2)

- 1 | 20d
- 2 | 50d
- 3 | 100d

14.1.4 Set the balance's response.

Alternatively, the balance's response of the balance can be set in the menu.

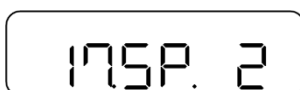

⇒ In the menu navigate to **<17. SP.>** and select setting (navigation in the menu: see chapter 8.2)

- 1 | fast reaction (animal does not move at all / hardly)
- 2 | medium reaction (animal moves a moderate amount)
- 3 | slow reaction (animal moves a lot)

15 Weighing with tolerance range

Setting a tolerance range allows you to quickly check whether a weight value is within certain limits.

This is where you can either set a single tolerance value (minimum value as lower limit) or a tolerance range (minimum and maximum value as lower and upper limit).



- Weighing with tolerance range is available for the following applications: Weighing, percentage weighing, piece counting and coefficient multiplication.
- <2. SEL 0> is the default setting (function deactivated).

Weight values can be evaluated in two ways when weighing with a tolerance range:

- Evaluation of absolute values
 - The evaluation is based on the permissible maximum and / or minimum value specified.
- Evaluation with difference values
 - The evaluation is based on a specified reference value and the permissible difference values.

Example:

A sample may weigh a minimum of 900.0 g and a maximum of 1200.0 g. The table below shows which values must be specified for the respective differentiation methods.

Distinguishing method	Reference value	Lower tolerance limit	Upper tolerance limit
Absolute values	1000.0 g	1.000kg	1.000kg
Differential values	1000.0 g	- 100.0 g	200.0 g

The following steps are needed to use weighing in the tolerance range,:

1. Select function (see chapter 15.1)
2. Set differentiation condition (see chapter 15.2)
3. Set differentiation range (see chapter 15.3)
4. Set the number of tolerance limits (see chapter 15.4)
5. Set discrimination method (see chapter 15.5)
6. Activate / deactivate acoustic signal (see chapter 15.6)
7. Set tolerance values (see chapter 15.7)
8. Set the display of the results (see chapter 15.8)

15.1 Selection of weighing function with tolerance range



⇒ In the menu select **<2. SEL 2>** (navigation in the menu: see chapter 8.2)

If the add-on function needs to be used at the same time, select **<2. SEL 3>**.

15.2 Set discrimination condition

The discrimination condition defines whether the evaluation of weight values is performed only if there are stable weight values or continuously (in case of fluctuating / non-stable weight values). The continuous assessment of weight values enables you to follow in real time on the display during dynamic weighing processes (e.g. when filling a container) whether your sample is within the tolerance limits.



⇒ In the menu navigate to **<21. Co.>** and select discrimination condition (Navigation in the menu: see chapter 8.2)

- | | |
|---|---------------------------------|
| 1 | Always |
| 2 | Only with steady weighing value |

15.3 Setting the discrimination range

The differentiation range determines the weight value from which the balance starts to evaluate this value. If the entire range is set, the balance starts at 0 g. If 5 is set, the adjustment for the weighing systems is based on the table below:

Model	Minimum weight for assessment
PWS 3000-1, PWS 8000-1	0.5 g
PWS 800-2	0.05 g

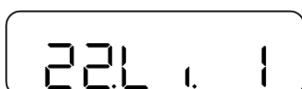

⇒ In the menu navigate to **<22. Li.>** and select Distinction Area (Navigation in the menu: see chapter 8.2)

- | | |
|---|--------------|
| 0 | +5 d or more |
| 1 | Whole range |

15.4 Set the number of tolerance limits

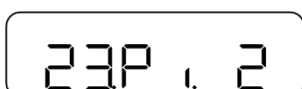

⇒ In the menu navigate to **<23. Pi.>** and select the number of tolerance limits (navigation in the menu: see chapter 8.2)

- | | |
|---|----------------------------------|
| 1 | Lower tolerance limit only |
| 2 | Upper and lower tolerance limits |

15.5 Set discrimination method

- ⇒ In the menu navigate to **<24. tP.>** and select the discrimination method (navigation in the menu: see chapter 8.2)



- | | |
|---|---|
| 1 | Assessment with absolute values (Setting the absolute values: see chapter 15.7.1) |
| 2 | Assessment with difference values (Setting the difference values: see chapter 15.7.2) |

15.6 Set acoustic signal

- ⇒ Navigate menu to **<25. b. 1>**, **<26. b. 2>** or **<27. b. 3>** (Navigation in the menu: see chapter 8.2)

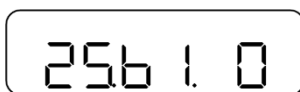

- | | |
|--------|---|
| 25. b1 | Buzzer for falling below the lower tolerance limit |
| 26. b2 | Buzzer for weighing result being within the tolerance range |
| 27. b3 | Buzzer sounds if the upper tolerance limit is exceeded. |

- ⇒ Select desired setting

- | | |
|---|-----------------------------|
| 0 | Acoustic signal deactivated |
| 1 | Acoustic signal activated |

15.7 Setting the tolerance values



- Tolerance values can only be saved when the balance is in the measurement mode display
- Zero (see chapter 9.2) or tare (see chapter 9.3) the balance before saving tolerance values.
- If the tolerance limits are not divided according to their order of magnitude (for example, the lower tolerance limit is greater than the upper tolerance limit), three arrows light up on the left of the display:

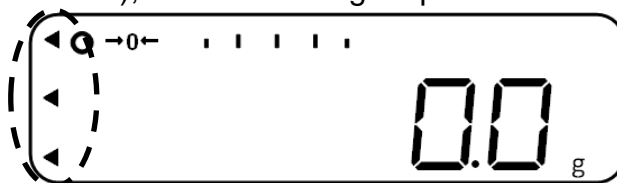

In this case, enter the tolerance limits again

15.7.1 Absolute values

Actual value setting method:

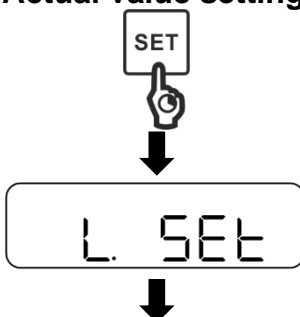

- ⇒ When the balance is in the measuring mode, hold down the **[SET]** key for about 2 seconds.

- ⇒ When **<L. SEt>** is displayed, release **[SET]** key



⇒ Last stored value for the lower tolerance limit flashes on the display (in this example: Weight value)

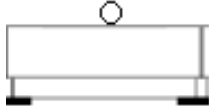

⇒ Place the reference sample for the lower tolerance limit on the weighing plate.



⇒ Press the **[F]** key to save the reference value.

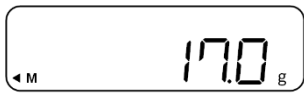

⇒ Value of the reference sample is displayed briefly (in this example: Weight value)

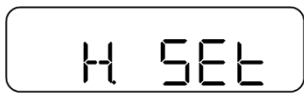

If the number of tolerance limits is 2:

⇒ The display shows <H. SEt>

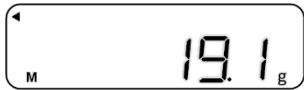

⇒ The last value stored for the upper tolerance limit flashes on the display



⇒ Place reference sample for the upper tolerance limit on the weighing plate



⇒ Press the **[F]** key to save the reference value.

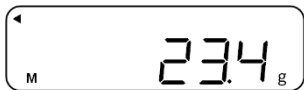

⇒ Value of the reference sample is displayed briefly (in this example: Weight value)

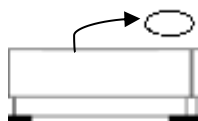

Weighing the samples:

⇒ Remove reference sample

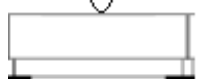

⇒ Place goods onto the weighing plate

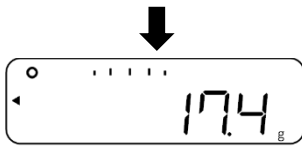

⇒ Evaluation of the value is shown on the display

Numeric input:



⇒ When the balance is in the measuring mode, hold down the **[SET]** key for about 2 seconds.

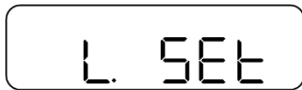

⇒ When **<L. SEt>** is displayed, release **[SET]** key



⇒ Last value stored for the lower tolerance limit flashes on the display



⇒ Press **[TARE/ZERO]** key



⇒ **<0>** flashes on the display

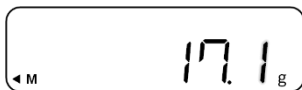

⇒ Enter lower tolerance limit (Numeric entry: see chapter 9.6)



⇒ Press the **[SET]** key to save the entry.

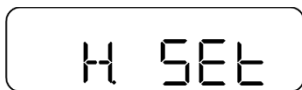

If the number of tolerance limits is 2:

⇒ The display shows **<H. SEt>**

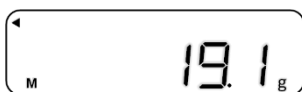

⇒ The last value stored for the upper tolerance limit flashes on the display



⇒ Press **[TARE/ZERO]** key

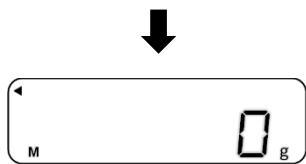

⇒ <0> flashes on the display

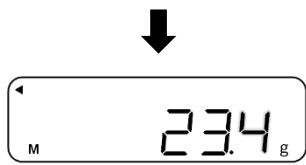

⇒ Enter upper tolerance limit (Numeric entry: see chapter 9.6)



⇒ Press the [SET] key to save the entry.

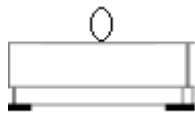

Weighing the samples:

⇒ Place goods onto weighing plate

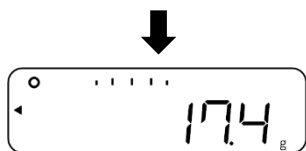

⇒ Evaluation of the value is shown on the display

15.7.2 Differential values

Actual value setting method:



⇒ When the balance is in the measuring mode, hold down the [SET] key for about 2 seconds.

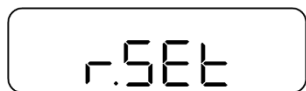

⇒ Release the [SET] key when <r. SET> is displayed.

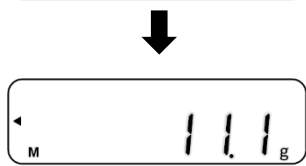

⇒ Last reference value stored flashes on the display

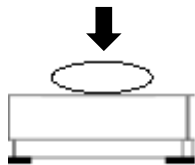

⇒ Place reference sample (target weight) on weighing plate



⇒ Press the [F] key to save the reference value.

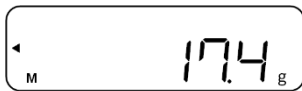

⇒ Value of reference sample is displayed briefly

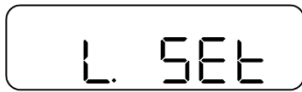

⇒ <L. SEt> is displayed



⇒ Last difference to reference sample flashes on the display

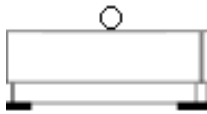

⇒ Place the reference sample for the lower tolerance limit on the weighing plate.



⇒ Press the [F] key to save the reference value.

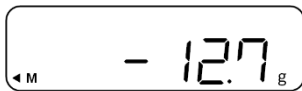

⇒ Difference to reference sample is displayed briefly

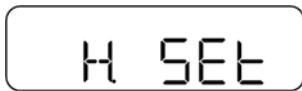

If the number of tolerance limits is 2:

⇒ The display shows <H. SEt>

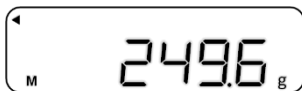

⇒ Last difference to reference sample flashes on the display



⇒ Place reference sample for the upper tolerance limit on the weighing plate



⇒ Press the [F] key to save the reference value.

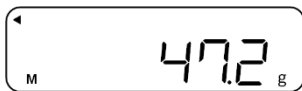

⇒ Difference to reference sample is displayed briefly



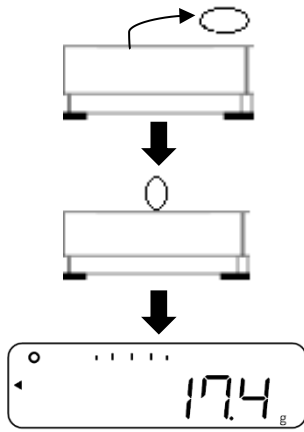

Weighing the samples:

- ⇒ Remove reference sample
- ⇒ Place weighing goods onto weighing plate
- ⇒ Evaluation of the value is shown on the display

Numeric input:

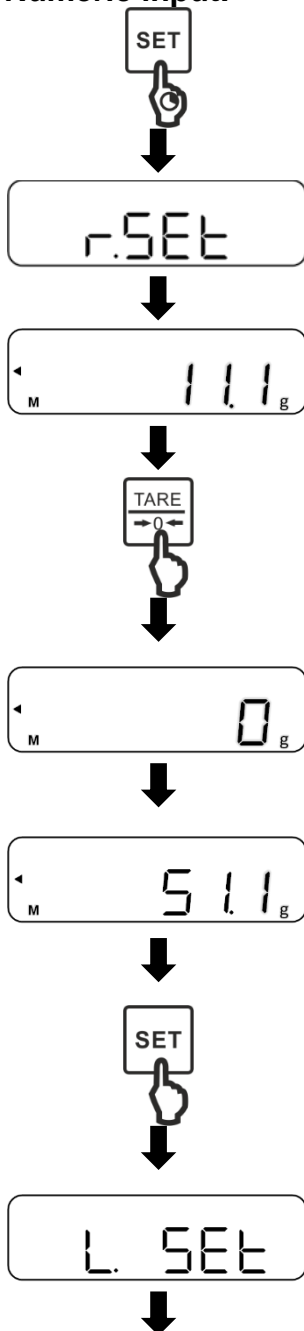

- ⇒ When the balance is in the measuring mode, hold down the **[SET]** key for about 2 seconds.
- ⇒ Release the **[SET]** key when **<r. SEt>** is displayed.
- ⇒ Last reference value stored flashes on the display
- ⇒ Press **[TARE/ZERO]** key
- ⇒ **<0>** flashes on the display
- ⇒ Enter reference value (target weight) (Numeric entry: see chapter 9.6)
- ⇒ Press the **[SET]** key to save the entry.
- ⇒ The display shows **<L. SEt>**

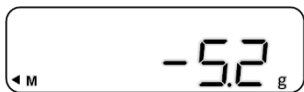

⇒ The last difference (lower tolerance limit) to the reference value flashes on the display



⇒ Press **[TARE/ZERO]** key

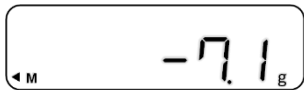

⇒ Enter difference as lower tolerance limit (Numeric entry: see chapter 9.6)



⇒ Press the **[SET]** key to save the entry.

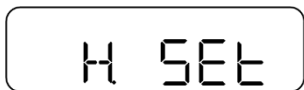

If the number of tolerance limits is 2:

⇒ The display shows **<H. SEt>**



⇒ The last difference (upper tolerance limit) to the reference value flashes on the display.



⇒ Press **[TARE/ZERO]** key



⇒ Enter the difference as the upper tolerance limit (numerical input): see chapter 9.6)



⇒ Press the **[SET]** key to save the entry.

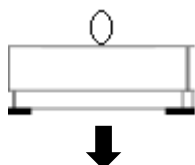

Weighing the samples:

⇒ Place goods onto weighing plate

16 Totalization

The **Totalizing** application allows you to weigh different samples and totalize the weight values. This function can be used for various applications, such as weighing individual batches to determine total stock.



- Totalizing is available for the following applications: Weighing, percentage weighing, piece counting and coefficient multiplication.
- **<2. SEL 0>** is the default setting (function deactivated).

Totalizing can be done in two ways:

- Totalizing individual weight values by replacing the sample on the weighing plate: TOTAL-Adding (see chapter 16.2.1)
- Totalizing of single weight values without exchanging the sample on the weighing plate (balance tares automatically after totalizing): NET-Adding (see chapter 16.2.2).

16.1 Select the Totalizing function



⇒ Select **<2. SEL 1>** in the menu (navigation in the menu: see chapter 8.2)

Select **<2. SEL 3>** if the tolerance function needs to be used at the same time,

⇒ Press **[F]** key

⇒ The display shows **<2C.Ad.>**.

⇒ Use the **[↑]** and **[↓]** keys (or **[TARE/ZERO]** key) to select the desired reference quantity.

- 1 TOTAL-Adding Totalizing individual weight values by replacing the sample on the weighing plate
- 2 NET-Adding: Totalize individual weight values without replacing the sample on the weighing plate (balance tares automatically after totalizing)

⇒ Press the **[SET]** key to save settings and return to measuring mode.

16.2 Using the totalizing function



- The error message **<t-Err>** appears if you have not placed the samples correctly (More information: see chapter 22.1)
- You can use the stabilisation waiting time (see chapter 17.5.2) to set whether the balance should wait for a stable weight value before the total is calculated

16.2.1 TOTAL-Adding

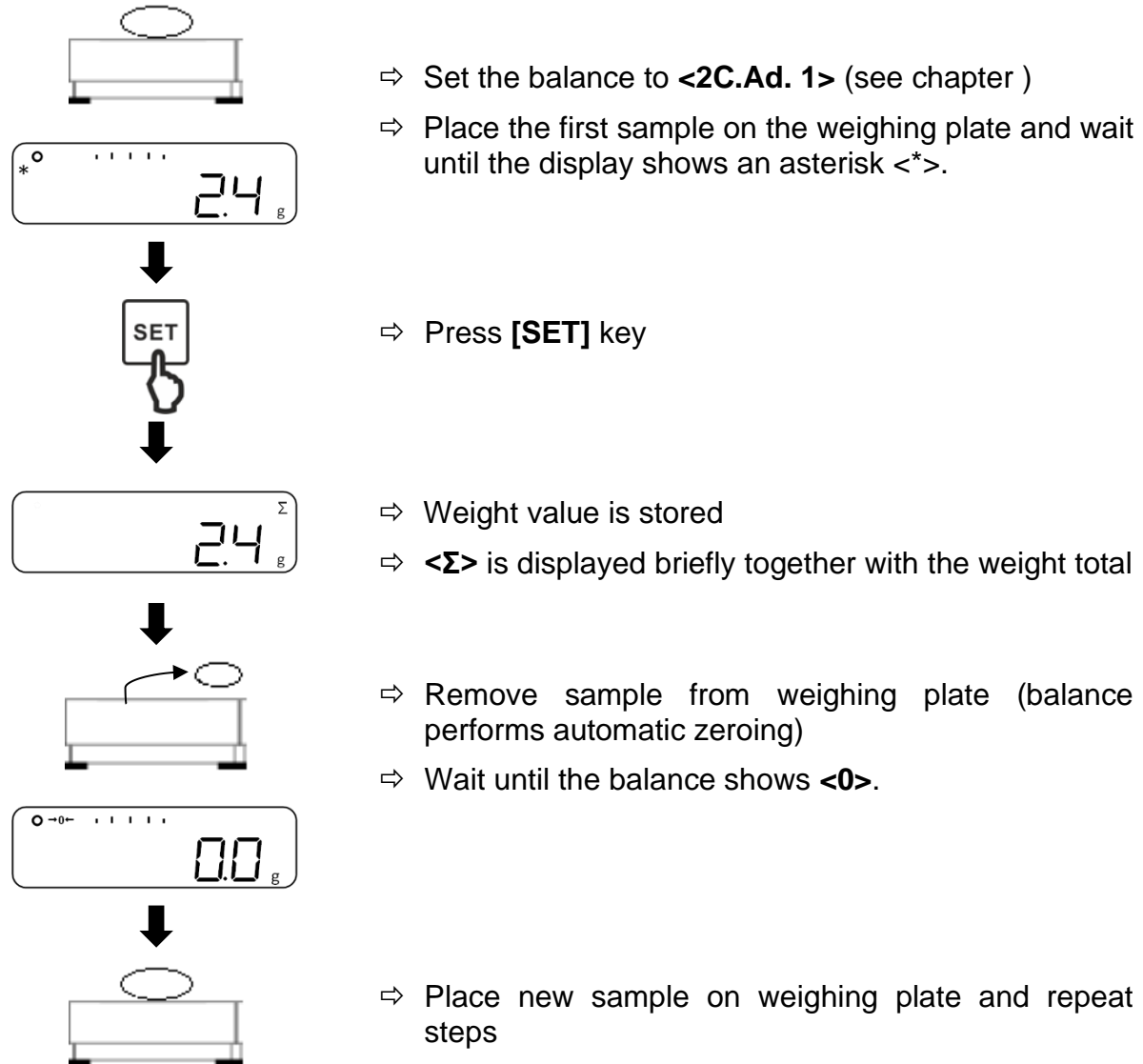

16.2.2 NET-Adding

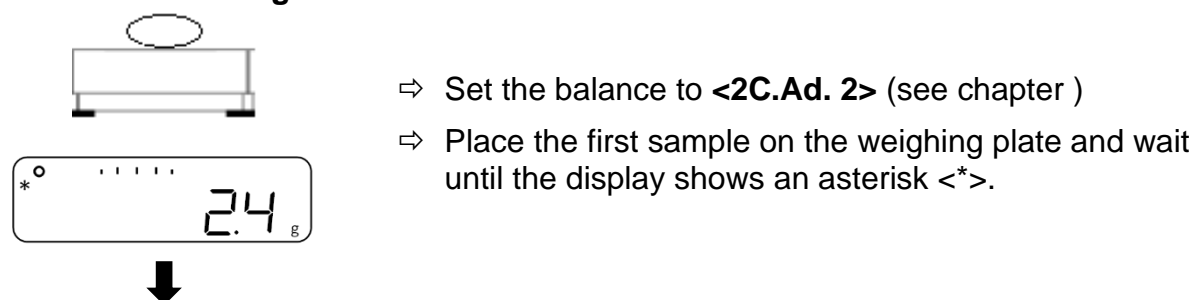

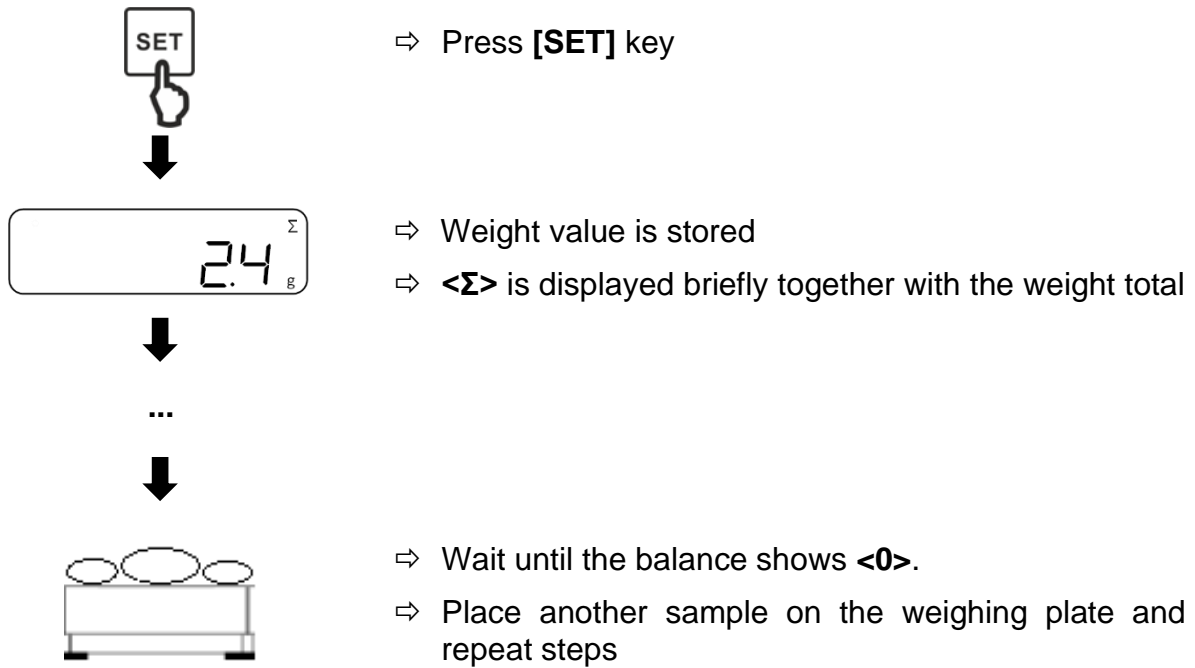

16.3 Show or clear the total sum

Show the total sum:



- ⇒ With the balance in measuring mode, press the **[F]** key repeatedly until the display shows $\langle \Sigma \rangle$.

Clear the total sum:



- ⇒ With the balance in measuring mode, press the **[F]** key repeatedly until the display shows $\langle \Sigma \rangle$.



- ⇒ Press **[TARE/ZERO]** key

17 Settings for operation and operating behaviour

Settings on the balance can be changed from the menu by pressing the **[F]** key.



For navigation in the menu see chapter 8.2

17.1 Setting the weighing units

Two weighing units (A and B) can be set on the balance. During weighing, the display can be switched between these two units by pressing the **[F]** key.



- ⇒ Unit A can be used for all weighing applications.
- ⇒ Unit B can be used for simple weighing only

⇒ In the menu navigate to **<b1.u.A>** or **<b3.ub>**.

<b1.u.A> | Set unit A

<b3.ub> | Set unit B

⇒ Select setting

0 | Disabled (setting only available for unit B).

1 | g (gram)

2 | kg (kilogram)

4 | ct (carat)

5 | Ounce

6 | Pound

7 | Troy ounce

8 | Penny weight

9 | Gran

A | Hongkong tael

b | Singapore-Malaysia tael

C | Taiwan tael

d | Momme

E | Indian tola

b 1 u A |

or

b 3 u b |

17.2 Bar graph display

The balance's bar graph display shows how much the weighing plate is loaded with respect to its weighing range.



⇒ Navigate to **<8. b.G.>** in the menu and select display setting

0	Disabled
1	Enabled

17.3 Acoustic signal

The acoustic signal supplements the display on the balance and can support you in your work.

On the balances you can set an acoustic signal to sound in the following cases:

- Piece weight has been updated in the Simple SCS function
- Weight value has been added
- Error message appears
- Low battery charge (for balances with batteries)
- Weight value has been evaluated in the tolerance range during weighing

17.3.1 Activate / deactivate the acoustic signal

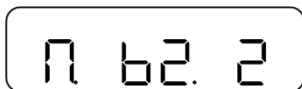

⇒ In the menu navigate to **<M. b2.>** and select setting

0	Disabled
1	Activated (acoustic signal in cases mentioned above)
2	When the button is pressed and in the above cases

17.3.2 Adjusting the sound level of the acoustic signal



⇒ Activate acoustic signal (see chapter 17.3.1)

⇒ In the menu navigate to **<M1. tn.>** and select setting

1	Low
2	Medium
3	High

17.4 Background lighting

The background lighting makes the display easier to read. The background lighting can be switched off automatically if the balance has not been used for more than three minutes.



- In the following cases, the backlight is not switched off:
 - when the menu of the balance is open
 - when there is a load on the weighing plate and the value is unstable.
- The background lighting is automatically switched on again when the balance is used.

17.4.1 Turn off of the background lighting automatically



⇒ In the menu, go to **<A. A.b.>** and select the response setting.

- | | |
|---|--|
| 0 | No automatic switch-off |
| 1 | Automatic switch-off after three minutes |

17.4.2 Checking the background lighting

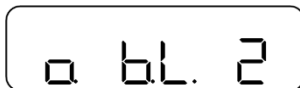

⇒ Navigate to **<o. b.L.>** in the menu and select reaction setting.

- | | |
|---|--|
| 0 | Disabled |
| 1 | Enabled |
| | Activated if the balance is operated with mains voltage |
| 2 | Deactivated if the balance is operated by rechargeable batteries |

17.5 Stability settings

The stability settings influence the evaluation of weight fluctuations on the weighing plate and to what extent the weight value is displayed as a stable value.

As a rule: **The larger the value set, the greater weight fluctuations can be for the weight value to be displayed as stable.**

17.5.1 Sensitivity

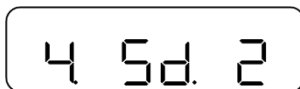

⇒ In the menu navigate to **<4. Sd.>** and select Sensitivity.

- | | |
|---|--|
| 1 | Very strong sensitivity |
| 2 | Increased sensitivity (default) |
| 3 | Weaker sensitivity (default) |
| 4 | Very weak sensitivity (anti-vibration) |

17.5.2 Stabilisation waiting time

You can set the balance to display the weight value even if the weight value is not yet stable after zeroing or taring.



⇒ In the menu navigate to **<H. tA.>** and select sensitivity.

- | | |
|---|----------|
| 1 | Disabled |
| 2 | Enabled |

17.6 Reaction settings

The reaction settings allow you to adapt the balance to the environmental conditions. The reaction setting affects the stability display of the balance.

The following applies: **The higher the value set, the less sensitive the balance is to environmental influences (e.g. wind or vibration) and is more likely to display a stable weight value.**

⇒ In the menu navigate to **<5. rE.>** and select Reaction setting.



0	Sensitive
1	Very strong sensitivity
2	Strong sensitivity
3	Normal
4	Weak sensitivity
5	Very weak sensitivity (anti-vibration)

17.7 Zero-Tracking

Small weight variations (e.g. due to particles on the weighing plate) can be automatically tared by zero tracking.

⇒ Navigate to **<3. A.0>** in the menu and select the setting.



0	Disabled
1	Enabled

17.8 Automatic switch-on function

If the autpower off switch is activated, the balance will automatically switch off if it has not been used after a period of 5 minutes.



- This function can only be used when the balance is operating on rechargeable battery power
- The balance does not switch off automatically,
 - when the menu of the balance is open
 - when there is a load on the weighing plate and the value is unstable.

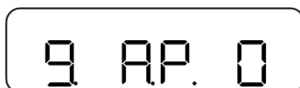

⇒ In the menu navigate to **<9. A.P.>** and select the setting.

0	Disabled
1	Enabled

18 System Settings

Settings on the balance can be changed from the menu by pressing the **[F]** key.



For navigation in the menu see chapter 8.2

18.1 Balance identification number

Your balance can be distinguished from other balances by assigning a balance identification number. The balance identification number is shown on the adjustment record.



A maximum of 6 characters can be assigned for the balance identification number

Set the balance identification number:



+



⇒ Press **[F]** key and **[TARE/ZERO]** key simultaneously for about 2 seconds.

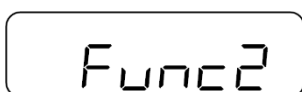

⇒ Release the keys when **<Func 2>** is displayed.

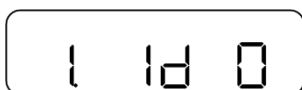

⇒ The display shows **<1. Id 0>**.



⇒ Select setting 1

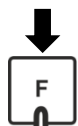

⇒ Press **[F]** key



Enter the balance identification number:

⇒ The balance identification number is displayed on the balance.



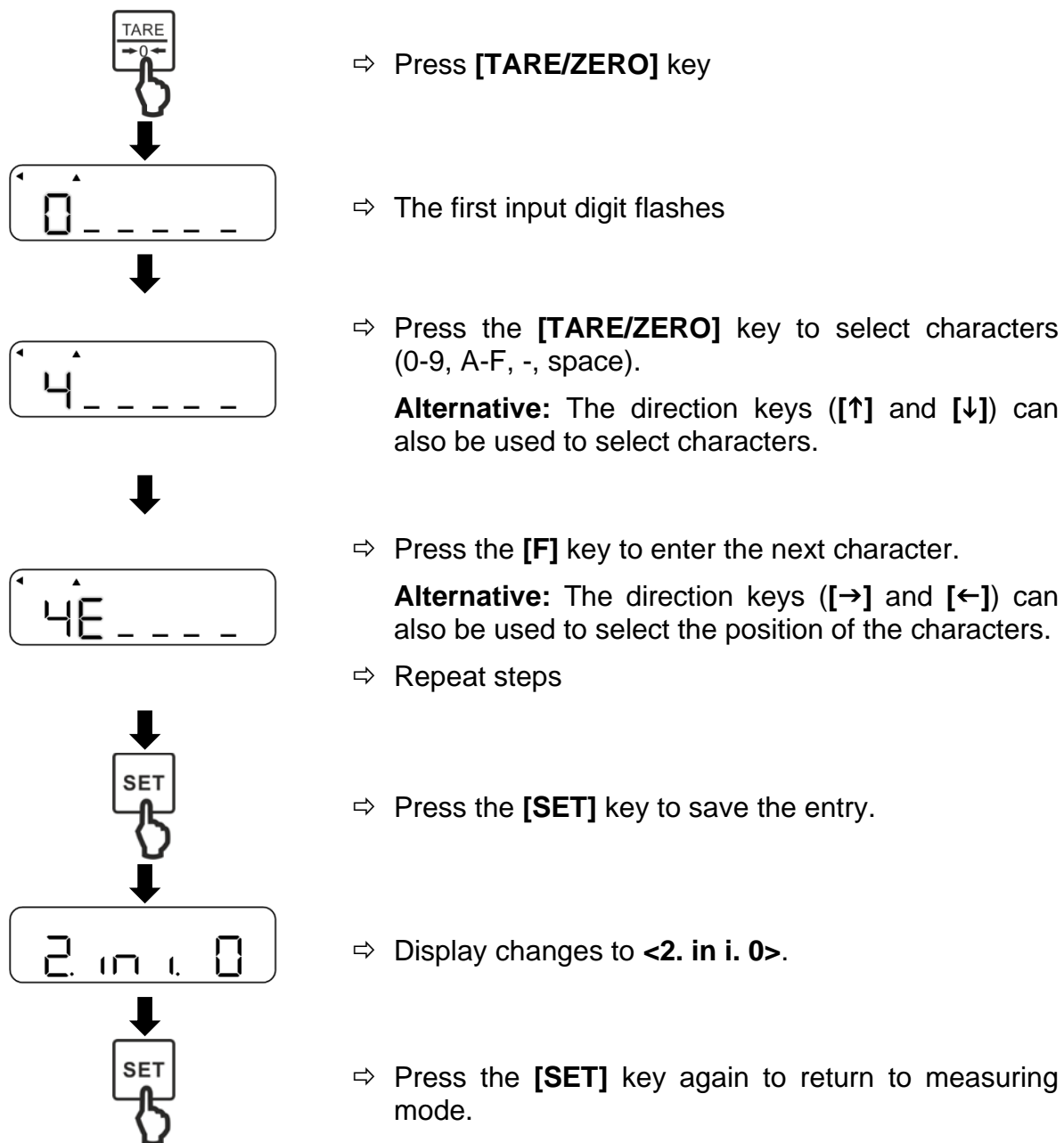

18.2 Readability

The greater the readability is set, the less the balance is affected by external influences. In addition, the scale value stabilises more quickly.



- The permissible readability differs depending on the weighing unit (see chapter
- For unit A and unit B (setting the weighing unit: see chap. 17.1) the readability can be set individually



or



⇒ In the menu navigate to **<b2. dA>** or **<b4. db>** and select readability

b2. dA | Readability for unit A

b4. db | Readability for unit B

⇒ Select readability (see chapter 18.2.1 and 18.2.2).

18.2.1 Readabilities for PWS 800-2

Setting	1	2	3	4	5
Gram	0.01	0.02	0.05	0.1	0.2
Kilogram	0.00001	0.00002	0.00005	0.0001	0.0002
Carat	0.05	0.1	0.2	0.5	1
Ounce	0.0005	0.001	0.002	0.005	0.01
Pound	0.00005	0.0001	0.0002	0.0005	0.001
Troy ounce	0.0005	0.001	0.002	0.005	0.01
Penny weight	0.01	0.02	0.05	0.1	0.2
Grain	0.2	0.5	1	2	5
Hong Kong tael	0.0005	0.001	0.002	0.005	0.01
Singapore-Malaysia tael	0.0005	0.001	0.002	0.005	0.01
Taiwan tael	0.0005	0.001	0.002	0.005	0.01
Momme	0.005	0.01	0.02	0.05	0.1
Indian tola	0.001	0.002	0.005	0.01	0.02

18.2.2 Readabilities for PWS 3000-1 and PWS 8000-1

Setting	1	2	3	4	5
Gram	0.1	0.2	0.5	1	2
Kilogram	0.0001	0.0002	0.0005	0.001	0.002
Carat	0.5	1	2	5	10
Ounce	0.005	0.01	0.02	0.05	0.1
Pound	0.0005	0.001	0.002	0.005	0.01
Troy ounce	0.005	0.01	0.02	0.05	0.1
Penny weight	0.1	0.2	0.5	1	2
Grain	2	5	10	10	10
Hong Kong tael	0.005	0.01	0.02	0.05	0.1
Singapore-Malaysia tael	0.005	0.01	0.02	0.05	0.1
Taiwan tael	0.005	0.01	0.02	0.05	0.1
Momme	0.05	0.1	0.2	0.5	1
Indian tola	0.01	0.02	0.05	0.1	0.2

18.3 Restore last tare value

The balance provides the option to restore the last tare value used before the balance was switched off when it is switched on again. If this function is activated, users do not need to tare again in the event of a power failure, for example, if the same tare weight is used.



If the weighing plate is permanently loaded over a longer period of time, this can lead to incorrect weighing results.

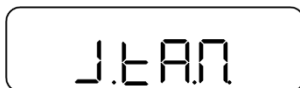

⇒ Navigate to **<L.tA.M.>** in the menu and select settings.

0	Disabled
1	Enabled

18.4 Restore factory settings

When restoring the balance's factory settings, all settings will be reset.

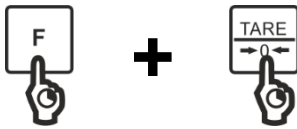

⇒ Press **[F]** key and **[TARE/ZERO]** key simultaneously for about 2 seconds.



⇒ Release the keys when **<Func 2>** is displayed.

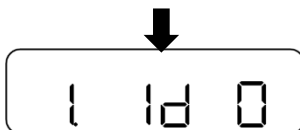

⇒ The display shows **<1. Id 0>**.



⇒ Press the **[F]** key to navigate to **<2. ini.>**.

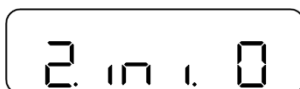

⇒ Select desired setting

0	Cancel
1	Restore factory settings



⇒ Press **[SET]** key

⇒ The balance returns to measuring mode

19 Adjustment

As the acceleration value due to gravity is not the same at every location on earth, each balance must be coordinated - in compliance with the underlying physical weighing principle - to the existing acceleration due to gravity at its place of location (only if the balance has not already been adjusted to the location in the factory).

This adjustment process must be carried out for the first commissioning, after each change of location as well as in case of fluctuating environment temperature. To receive accurate measuring values it is also recommended to adjust the balance periodically in weighing operation.



- Observe stable environmental conditions. A warm up time (see chapter 1) is required for stabilization.
- Ensure that there are no objects on the weighing pan.
- Avoid vibration and air flow.
- Always carry out adjustment with the standard weighing plate in place.
- The adjustment record is printed if an optional printer is connected and the GLP function has been activated.

19.1 Adjustment



- You can cancel the adjustment procedure if you press a key during adjustment (except **[F]** key)
- The error messages **<1-Err>** or **<2-Err>** appear if you have not applied the correct adjustment weight (More information: see chapter 22.1)
- Setting **<7. CA. 0>** disables the adjustment function.

7 CA. 3

⇒ In the menu select **<7CA. 3>** (Navigation in the menu: see chapter 8.2)



⇒ Press **[SET]** key



CAL.

⇒ Hold down **[F]** key until **<CAL>** appears on the display.

⇒ Release **[F]** key



on 0

⇒ Message **<on 0>** appears on the display and starts flashing

⇒ The balance performs a zero setting

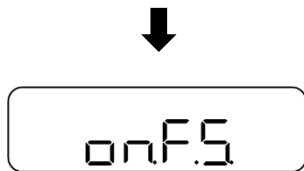

⇒ The message **<on F.S.>** is displayed when zeroing is complete

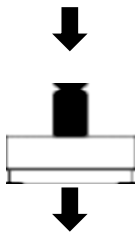

⇒ Place the adjustment weight centrally on the weighing plate.

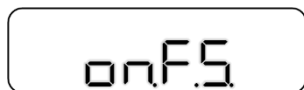

⇒ Message **<on F.S.>** starts flashing on the display
⇒ Adjustment starts

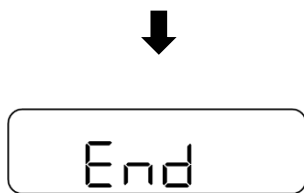

⇒ The adjustment has been completed once **<End>** is displayed on the balance
⇒ The balance returns to measuring mode
⇒ Unload weighing plate

19.2 Adjustment test



⇒ In the menu select **<7.CA. 4>** (navigation in the menu: see chapter 8.2)



⇒ Press **[SET]** key
⇒ The balance returns to measuring mode



⇒ Press and hold the **[F]** key for about 2 seconds.

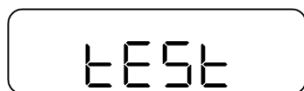

⇒ Display changes to **<tEst>**.
⇒ Release **[F]** key

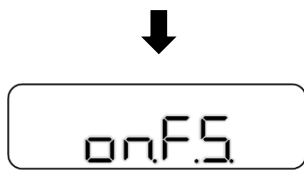

⇒ **<on 0>** and **<on F.S.>** appear on the display one after the other



- ⇒ Place the adjustment weight on the weighing plate once the balance shows **<on F.S.>**.
- ⇒ The adjustment test starts automatically

- ⇒ The display first shows **<d IFF>** and then the difference value between the adjustment weight and the actual weight value
- ⇒ Press any key to return to the measuring mode.

20 Interfaces

The balance can communicate with external peripherals using the interface. Data can be sent to a printer, PC or control displays. In the same way, control commands and data inputs may occur via the connected devices (such as PC, keyboard, barcode reader).

20.1 RS-232C interface for data input and output

The balance is equipped as per standard with an RS232C interface to connect a peripheral device (e.g. printer or computer).

20.1.1 Technical data

Connection	9 pin d-subminiature bushing
Baud rate	Optional 1200/2400/4800/9600/19200
Parity	Empty / Odd number / Even number

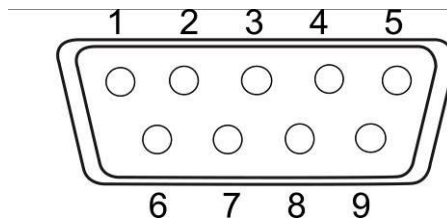

Pin connection:

Pin nr.	Signal	Input/Output	Function
1	-	-	-
2	RXD	Input	Receive data
3	TXD	Output	Edit data
4	DTR	Output	HIGH (when balance is switched on)
5	GND	-	Signal ground
6	-	-	-
7	-	-	-
8	-	-	-
9	EXT. TARE	Input	External contact input for tare subtraction



The tare subtraction can be performed by an external device by connecting a contact or a transistor switch between pin 9 (EXT. TARE) and pin 5 (GND). A switch-on time of at least 400 ms must be observed (open-circuit voltage: 15 V when the balance is switched off, leakage current: 20 mA, when it is switched on).

20.1.2 Interface cable

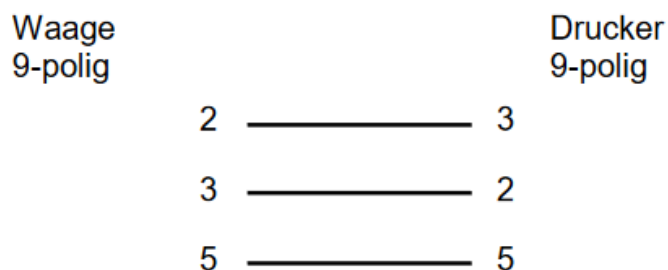
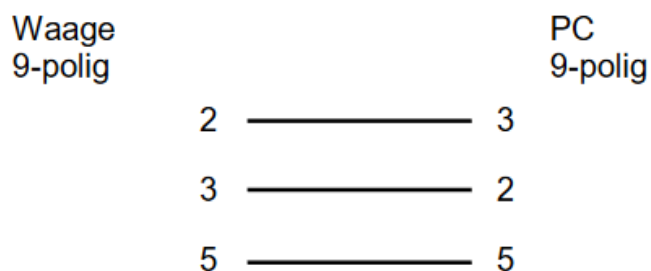

20.2 Data output formats

20.2.1 Data composition

- **6-digit data format**

Consisting of 14 characters, including the end characters (CR= 0DH, LF= 0AH)*.

1	2	3	4	5	6	7	8	9	10	11	12	13	14
P1	D1	D2	D3	D4	D5	D6	D7	U1	U2	S1	S2	CR	LF

- **7-digit data format**

Consisting of 15 characters, including the end characters (CR= 0DH, LF= 0AH)

1	2	3	4	5	6	7	8	9	10	11	12	13	14	15
P1	D1	D2	D3	D4	D5	D6	D7	D8	U1	U2	S1	S2	CR	LF

- **Extended 7-digit data format**

- o Extended version of the 7-digit data format
- o Data length can be 7 to 9 bits
- o Stop bit length can be 1 to 2 bits
- o If you have set the output language to Japanese, the data length is automatically 8 bits

20.2.2 Data description

Presign:

P1 = 1 character

P1	Code	Significance
+	2BH	Data is 0 or positive
-	2DH	Data is negative

Numeric data:

D1-D7/D8	Code	Significance
0 – 9	30H – 39H	Numbers 0 to 9
.	2EH	Decimal point (position not fixed)
Sp	20H	Space before numeric data If numeric data does not contain a decimal point, a space is output at the least significant digit and no decimal point is output

*Sp = space

Units:

U1, U2 = 2 characters: To indicate the unit of the numerical data

U1	U2	Code (U1)	Code (U2)	Significance	Symbol
Sp	G	20H	47H	Gram	g
K	G	4BH	47H	Kilogram	kg
C	T	43H	54H	Carat	ct
O	C	4FH	5AH	Ounce	oz
L	B	4CH	42H	Pound	lb
O	T	4FH	54H	Troy ounce	ozt
D	W	44H	57H	Penny weight	dwt
G	R	47H	52H	Grain	► (bottom right)
T	L	54H	4CH	Hongkong tael	tl
T	L	54H	4CH	Singapore-Malaysia tael	tl and ► (top right)
T	L	54H	4CH	Taiwan tael	tl and ► (middle right)
M	O	4DH	4FH	Momme	(mom)
t	o	74H	6FH	Indian tola	to
P	C	50H	43H	Pieces	Pcs
Sp	%	20H	25H	Percent	%
Sp	#	20H	23H	Calculation results	#

*Sp = space

Result evaluation for weighing with tolerance range:

S1 = 1 character

S1	Code	Significance
L	4CH	Below lower tolerance limit (LOW)
G	47H	Within tolerance range (OK)
H	48H	Upper tolerance limit exceeded (HIGH)
T	54H	Total
U	55H	Piece weight
Sp	20H	No evaluation result or data type specified
d	64H	Gross

*Sp = space

Status of data:

S2 = 1 character

S2	Code	Significance
S	53H	Data stable
U	55H	Data not stable
E	45H	Data error, all data except S2 unreliable
Sp	20H	No special status

*Sp = space

20.3 Data input



- Pay attention to upper and lower case letters when entering data
- Wait for the balance to respond between two entries

20.3.1 Input format

Input format:

1	2	3	4
C1	C2	CR	LF

Example of permanent output input:

⇒ Input: O0

Zeroing / taring, data output:

C1	C2	Code (C1)	Code (C2)	Significance
T	Sp	54H	20H	Set to zero/taring
O	0	4FH	30H	End output
O	1	4FH	31H	Permanent output
O	2	4FH	32H	Continuous output only for stable values (interruption of output for unstable values).
O	3	4FH	33H	Press [PRINT] key for one-time output
O	4	4FH	34H	Automatic output when weighing plate is loaded again and value is stable
O	5	4FH	35H	One-time output whenever value is stable (no output for unstable values)
O	6	4FH	36H	Continuous output for unstable values (interruption of output when value is stable → stable value is output once)
O	7	4FH	37H	Press [PRINT] key for one-time output at stable values (no output at unstable values)
O	8	4FH	38H	One-time output
O	9	4FH	39H	One-time output at stable value

*Sp = space

Response:	
A00:	Input successful
E01:	Input Error
E04:	Taring or zeroing cannot be carried out (range exceeded, weight error, ...)



- Commands O8 and O9 are used to request data.
- After entering O8 or O9, the balance returns O0.
- Commands O0 to O7 are executed after activation until the balance is turned off. The output settings are reset to factory settings when the balance is switched on again.

Weighing functions:



- The weighing function that can be activated by entering a mode depends on the weighing application currently in use on the balance (see mode table).
- Mode 3 can only be activated if the totalising function has been activated.
- If no unit B has been defined, mode 4 activates simple weighing

C1	C2	Code (C1)	Code (C2)	Significance
M	1	4DH	31H	Set mode 1
M	2	4DH	32H	Set mode 2
M	3	4DH	33H	Set mode 3
M	4	4DH	34H	Set mode 4

Mode table					
Mode	Simple weighing	Piece counting	Percent weighing	Density determination	Animal weighing
1	Weigh weight	Weigh weight	Weigh weight	Error	Error
2	Gross weight	Piece counting	Percent weighing	Error	Error
3	Totalise weight	Totalise pieces	Totalise percentage	Error	Error
4	Display unit B	Average piece weight	Error	Error	Error

Response:	
A00	Input successful
E01	Input Error
E02	Error

Adjustment / Adjustment test:

C1	C2	Code (C1)	Code (C2)	Significance
C	0	43H	30H	Deactivate entries
C	3	43H	33H	Perform adjustment with external weight
C	4	43H	34H	Perform adjustment test with external weight

Response:	
A00	Input successful
E01	Input Error
E02	Function has been deactivated
E03	Cancelled
E04	Incorrect execution

20.4 Response formats

Response	
A00/Exx Format	ACK/NAK Format
A00: Normal answer E01: Incorrect answer	ACK: Normal answer NAK: Incorrect answer

20.4.1 A00/Exx Format

Consists of 5 characters, including the end characters (CR= 0DH, LF= 0AH) *.

1	2	3	4	5
A1	A2	A3	CR	LF

* End characters: CR = paragraph, LF = line

Commands:

A1	A2	A3	Code (A1)	Code (A2)	Code (A3)	Significance
A	0	0	41H	30H	30H	Normal answer
E	0	1	45H	30H	31H	Incorrect answer

20.4.2 ACK/NAK Format

Consists of one character (without end characters).

1
A1

Commands:

A1	Code (A1)	Significance
ACK	06H	Normal answer
NAK	15H	Incorrect answer

20.5 Communication settings

Settings on the balance can be changed from the menu by pressing the **[F]** key.



For navigation in the menu see chapter 8.2

20.5.1 Enable / disable interface and data format

⇒ Navigate to **<6. I.F.>** in the menu and select data format

6. I.F. 1.

- 0 Deactivate the interface
- 1 6-digit data format
- 2 7-digit data format
- 3 Extended 7-digit data format

20.5.2 Change communication settings



The communication settings can only be made after the interface has been activated (see chapter 20.5.1).

Set output condition:

6 loc. 7

⇒ Navigate to **<61.oc.>** in the menu and select the desired setting.

- | | |
|---|--|
| 0 | End output |
| 1 | Permanent output |
| 2 | Continuous output only for stable values (interruption of output for unstable values). |
| 3 | One-time output when [PRINT] key is pressed |
| 4 | Automatic output (One-time output when the value is stable. The next output for another sample occurs when the reading is stabilised to less than or equal to zero by unloading, zero adjustment or tare subtraction). |
| 5 | One-time output whenever value is stable (no output for unstable values) |
| 6 | Continuous output for unstable values (interruption of output for stable value →; the stable value is output once) |
| 7 | Press [PRINT] key for one-time output at stable values (no output at unstable values) |

Set baud rate

62bL. 1

⇒ Navigate to **<62.bL.>** in the menu and select the desired setting.

- | | |
|---|-----------|
| 1 | 1200 bps |
| 2 | 2400 bps |
| 3 | 4800 bps |
| 4 | 9600 bps |
| 5 | 19200 bps |

Set parity:

 Parity can only be set if the interface is set to 2 or 3 (see chapter 20.5.1).

63PA. 0

⇒ Navigate to **<63.PA.>** in the menu and select the desired setting

- | | |
|---|-------|
| 0 | Empty |
| 1 | Odd |
| 2 | Even |

Set the data length:



The data length can only be set if the interface has been set to 3 (see chapter 20.5.1).

64dL. 8

⇒ In the menu navigate to **<64.dL.>** and select the desired setting.

- 7 | 7 Bit
- 8 | 8 Bit

Set stop bit:

65St. 2

⇒ In the menu navigate to **<65.dL.>** and select the desired setting

- 1 | 1 Bit
- 2 | 2 Bit

Set handling of blank digits:

66nu. 0

⇒ Navigate to **<66.nu.>** in the menu and select the desired setting

- 0 | Fill with 0 (30H)
- 1 | Fill with blank line (20H)

Set response format:

67rS. 1

⇒ In the menu navigate to **<67.rS.>** and select the desired setting

- 1 | Format: A00/Exx
- 2 | Format: ACK/NAK

20.6 Printer functions

Via the interfaces weighing data may be exchanged with connected peripheral devices.

Issue may be made to a printer, PC or check displays. In contrast, control commands and data entries can be made using the connected devices (e.g., PC, keyboard, barcode reader).



- The output of date and time depends on the printer used. Information on this can be found on our homepage:

www.kern-sohn.com

Activate output to peripheral devices:



⇒ Navigate to **<E.GLP>** in the menu and select the setting.

- 0 | Disabled
- 1 | Enabled

20.6.1 Output of the adjustment test result

The balance provides the option to automatically show the result on the interface after adjustment or after the adjustment test.

⇒ Select **<E.GLP 1>** (see chapter 20.6)

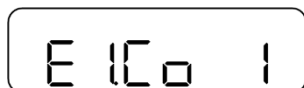

⇒ In the menu navigate to **<E1.Co>** and select the setting

- 0 | Automatic output deactivated
- 1 | Automatic output activated

20.6.2 Output of measurements obtained

The balance allows measurements to be output using the interface.

Activate the measurement result output:

⇒ Select **<E.GLP 1>** (see chapter 20.6)

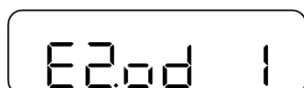

⇒ In the menu navigate to **<E2.od>** and select the setting

- 0 | Automatic output deactivated
- 1 | Automatic output activated

Output of measurements obtained:

Print header:



⇒ Press and hold the **[PRINT]** key.

Print measurements obtained:



⇒ Place goods onto weighing plate

⇒ Press **[PRINT]** key

Print footer:



⇒ Press and hold the **[PRINT]** key when the measurement of the weighing good is complete

20.6.3 Output language

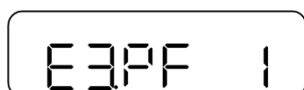

⇒ Set **<E.GLP>** to 1 (see chapter).

⇒ In the menu navigate to **<E3.PF>** and select the setting.

- 1 | English
- 2 | Japanese

21 Servicing, maintenance, disposal



Before any maintenance, cleaning and repair work disconnect the appliance from the operating voltage.

21.1 Cleaning

- ⇒ Comply with IP protection
- ⇒ Do not use aggressive cleaning agents (solvents or similar) only a cloth moistened with mild soapy water should be used.
- ⇒ Wipe with a dry, soft cloth.
- ⇒ Do not use cleaning agents that contain caustic soda, acetic acid, hydrochloric acid, sulphuric acid or citric acid on stainless steel parts.
- ⇒ Clean stainless-steel parts with a soft cloth soaked in a cleaning agent suitable for stainless steel.
- ⇒ Make sure that no liquid enters the instrument.
- ⇒ Do not use metal brushes or cleaning sponges of steel wool, as this causes superficial corrosion.
- ⇒ Loose sample residues/powder can be removed carefully with a brush or hand-held vacuum cleaner.
- ⇒ Remove spilled weighing material immediately

21.2 Servicing, maintenance

- ⇒ The appliance may only be opened by qualified service technicians authorised by KERN.
- ⇒ Before opening, disconnect from power supply.

21.3 Disposal

Disposal of packaging and appliance must be carried out by operator according to valid national or regional law of the location where the appliance is used.

22 Instant help for troubleshooting

In the event of a fault in the programme sequence, the balance should be briefly switched off and disconnected from the mains. The weighing process must then be restarted.

Fault	Possible cause
The weight display does not glow	<ul style="list-style-type: none"> • The balance is not switched on • The mains supply connection has been interrupted (mains cable not plugged in/faulty). • Power supply interrupted. • (Rechargeable) batteries are inserted incorrectly or empty • No (rechargeable) batteries inserted
The displayed weight is permanently changing	<ul style="list-style-type: none"> • Draught/air movement • Table/floor vibrations • Weighing plate has contact with other objects • Electromagnetic fields / static charging (choose different location/switch off interfering device if possible)
The weighing result is obviously incorrect	<ul style="list-style-type: none"> • The display of the balance is not at zero • Adjustment is no longer correct • The balance is on an uneven surface • Great fluctuations in temperature • Electromagnetic fields / static charging (choose different location/switch off interfering device if possible)
The weighing result is incorrect after adjustment	<ul style="list-style-type: none"> • Adjustment was not carried out under stable ambient conditions. • Differences in weight between the adjustment weight and the weight used for testing

Fault	Possible cause
The display does not change when the M symbol flashes	<ul style="list-style-type: none"> • Draught/air movement • Table/floor vibrations • Weighing plate has contact with other objects • Electromagnetic fields / static charging (choose different location/switch off interfering device if possible)
The battery symbol flashes	<ul style="list-style-type: none"> • The charge level of the batteries / rechargeable batteries is low
The display turns off when the balance is being operated using batteries / accumulators	<ul style="list-style-type: none"> • The automatic switch-off function has been activated

Should other error messages occur, switch balance off and then on again.
If the error message remains inform manufacturer.

22.1 Error messages

Error message	Description	Possible causes / repair
o-Err	<ul style="list-style-type: none"> • Maximum weighing range exceeded • The total exceeds the maximum number of characters on the display 	<ul style="list-style-type: none"> • Split sample and weigh individually • Use lighter tare weight • Delete the result of the calculation and perform the calculation again (pay attention to the display) • Coefficient of unit conversion is too small. Use larger coefficient. • Notify your supplier if the error message remains even though there is nothing on the weighing plate.
u-Err	<ul style="list-style-type: none"> • Negative load is below the minimum weighing range 	<ul style="list-style-type: none"> • Weighing plate or weighing plate carrier incorrectly adjusted • Check whether the balance is touching other objects • Contact your supplier if the error message persists even though the weighing plate and weighing plate support are correctly adjusted.
l-Err	<ul style="list-style-type: none"> • The weight value of the adjustment weight is less than 50 % of the weighing capacity. 	<ul style="list-style-type: none"> • Use an adjustment weight with a weight value as close as possible to the weighing capacity.



WolfLabs

Pricing on any accessories shown can be found by keying the part number into the search box on our website.

The specifications listed in this brochure are subject to change by the manufacturer and therefore cannot be guaranteed to be correct. If there are aspects of the specification that must be guaranteed, please provide these to our sales team so that details can be confirmed.

www.wolflabs.co.uk

Tel : 01759 301142

Fax : 01759 301143

sales@wolflabs.co.uk

Please contact us if this literature doesn't answer all your questions.