

# IKA

designed for scientists

**RCT** basic

ENGLISH

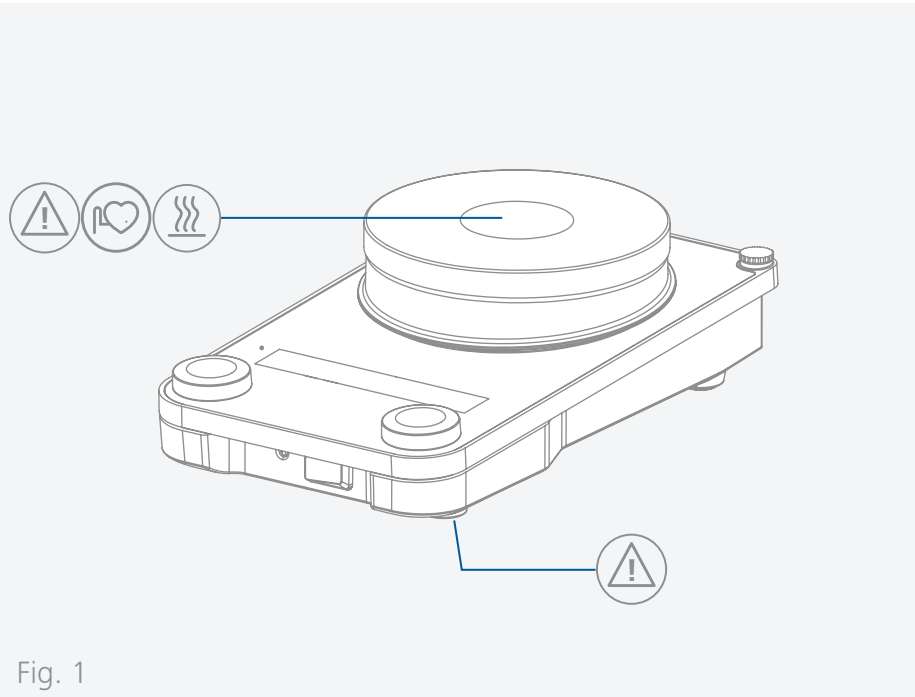









Fig. 1

	EU Declaration of conformity .....	6
	Explication of warning symbols .....	6
	Safety instructions.....	7
	Intended use.....	10
	Unpacking .....	11
	Installation.....	12
	Operator panel and display .....	15
	Operation .....	17
	Interfaces and outputs .....	25
	Maintenance and cleaning.....	28
	Accessories .....	28
	Error codes .....	29
	Technical Data .....	32
	Warranty .....	34



## EU Declaration of conformity

We declare under our sole responsibility that this product corresponds to the directives 2014/35/EU, 2006/42/EC, 2014/30/EU and 2011/65/EU and conforms with the following standards or normative documents: EN 61010-1, EN 61010-2-010, EN 61010-2-051, EN 61326-1, EN 60529 and EN ISO 12100.

A copy of the complete EU Declaration of Conformity or further declarations of conformity can be requested at [sales@ika.com](mailto:sales@ika.com).



## Explication of warning symbols

### /// Warning symbols

- Danger!** Indicates an (extremely) hazardous situation, which, if not avoided, will result in death, serious injury.
- Warning!** Indicates a hazardous situation, which, if not avoided, can result in death, serious injury.
- Caution!** Indicates a potentially hazardous situation, which, if not avoided, can result in injury.
- Notice!** Indicates practices which, if not avoided, can result in equipment damage.
- Attention!** Indicates the risks due to magnetism.
- Danger!** Indicates the exposure to a hot surface.

### /// General Symbols

- A** — Position number  
Indicates device components relevant to actions.
- Correct / result  
Indicates the correct execution or the result of an action step.
- Wrong  
Indicates the incorrect execution of an action step.
- Note  
Indicates steps of actions that require particular attention.

## Safety instructions



### /// General information

- > **Read the operating instructions completely before starting up and follow the safety instructions.**
- > Keep the operating instructions in a place where it can be accessed by everyone.
- > Ensure that only trained staff work with the device.
- > Follow the safety instructions, guidelines, occupational health and safety and accident prevention regulations.
- > Electrical outlet must be grounded (protective ground contact).

#### **Attention – Magnetism!**

- > Effects of the magnetic field have to be taken into account (e.g. data storage media, cardiac pacemakers ...).

#### **Risk of burns!**

- > Exercise caution when touching parts of the housing and the heating plate.
- > The heating plate can reach dangerous temperatures. Pay attention to the residual heat on the heating plate after switching off the stirrer.
- > The device may only be transported when the heating plate has cooled down.

#### **Notice!**

- > Pay attention to the marked sites in **Fig. 1**.

### /// Device design

#### **Caution!**

- > Device surface is partially made of glass:
  - Glass surface can be damaged by impact.
  - If glass surface is damaged it could cause injury, don't use the device anymore.

#### **Notice!**

- > Set up the device in a spacious area on an even, stable, clean, non-slip, dry and fireproof surface.
- > Observe the minimum distances:
  - between devices min. 100 mm,
  - between device and wall min. 100 mm,
  - above the device min. 800 mm.

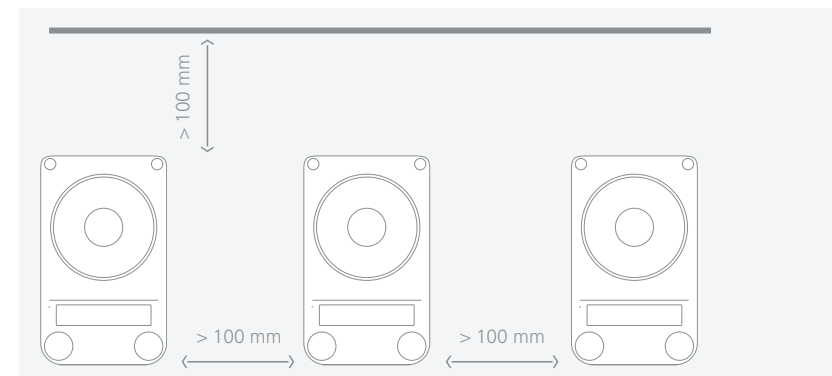

- › The feet of the device must be clean and undamaged.
- › Keep the base plate clean.
- › Protect the device and accessories from bumps and impacts.
- › Check the device and accessories for damage before each use. Do not use damaged components.
- › Ensure that the power cord set / temperature sensor cable does not touch the heating plate.
- › Do not cover the device, even partially e.g. with metallic plates or film. This may result in overheating.

### /// Working with the device

#### **Danger!**

- › Do not use the device in explosive atmospheres, it is not EX-protected.
- › With substances capable of forming an explosive mixture, appropriate safety measures must be applied, e.g. working under a fume hood.
- › To avoid body injury and property damage, observe the relevant safety and accident prevention measures when processing hazardous materials.

#### **Warning!**

- › Only process media that will not react dangerously to the extra energy produced through processing. This also applies to any extra energy produced in other ways, e.g. through light irradiation.
- › Beware of hazards due to:
  - flammable materials,
  - combustible media with a low boiling temperature,
  - glass breakage,
  - incorrect container size,
  - overfilling of media,
  - unsafe condition of container.
- › Process pathogenic materials only in closed vessels under a suitable fume hood.

#### **Caution!**

- › In unsupervised and safe operation, this device may only handle or heat media whose flash point is above the set safety temperature limit. The safety temperature limit must always be set to at least 25 °C lower than the flash point of the media used. (acc. to EN 61010-2-010)
- › Wear your personal protective equipment in accordance with the hazard category of the media to be processed. There may be a risk from:
  - splashing and evaporation of liquids,
  - ejection of parts,
  - release of toxic or combustible gases.
- › Reduce speed if:
  - medium splashes out of vessel because the speed is too high,
  - device is not running smoothly,
  - container moves on the base plate,
  - an error message is displayed.
- › The heating plate can heat up due to the action of the magnets at high motor speeds, even if the heater is switched off.
- › Please consider any possible contaminations and unwanted chemical reactions.
- › It may be possible for wear debris from rotating accessory parts to reach the material being processed.

- › When using PTFE-coated magnetic bars, the following has to be noted: Chemical reactions of PTFE occur in contact with molten or solute alkali metals and alkaline earth metals, as well as with fine powders of metals in groups 2 and 3 of the periodic system at temperatures above 300 °C – 400 °C. Only elementary fluorine, chlorotrifluoride and alkali metals attack it; halogenated hydrocarbons have a reversible swelling effect.

(Source: Römpps Chemie-Lexikon and "Ulmann", Volume 19)

### /// Accessories

- › Safe operation is guaranteed only with the use of original IKA accessories.
- › Ensure that the external temperature sensor is inserted into the medium to a depth of at least 20 mm when connected.
- › Always disconnect the plug before attaching accessories.
- › Accessories must be securely attached to the device and cannot come off by themselves. The centre of gravity of the assembly must lie within the surface on which it is set up.
- › Observe the operating instructions of the accessories.

### /// Power supply / Switching off the device

#### **Warning!**

- › The device will automatically restart in operating mode B following any interruption to the power supply.
- › The voltage stated on the type plate must correspond to the mains voltage.
- › The outlet for the mains plug must be easily accessible.
- › The device can only be disconnected from the power supply by pulling out the power plug or the connector plug.

### /// Maintenance

- › The device may only be opened by qualified and IKA approved experts. The device must be unplugged from the power supply before opening. Live parts inside the device may still be live for some time after unplugging from the power supply.

### /// Disposal instructions

- › The device, accessories and packaging must be disposed of in accordance with local and national regulations.



## Intended use

### /// Use

- › The magnetic stirrer is suitable for mixing and / or heating substances.

### /// Area of use

- › Indoor environments similar to that a laboratory of research, teaching, trade or industry area.
- › The safety of the user cannot be guaranteed:
  - if the device is operated with accessories that are not supplied or recommended by the manufacturer,
  - if the device is operated improperly or contrary to the manufacture's specifications,
  - if the device or the printed circuit board are modified by third parties.

## Unpacking



### /// Unpacking

- › Unpack the device carefully. Any damage should immediately be reported to the carrier (mail, rail or freight forwarding company).

### /// Scope of delivery

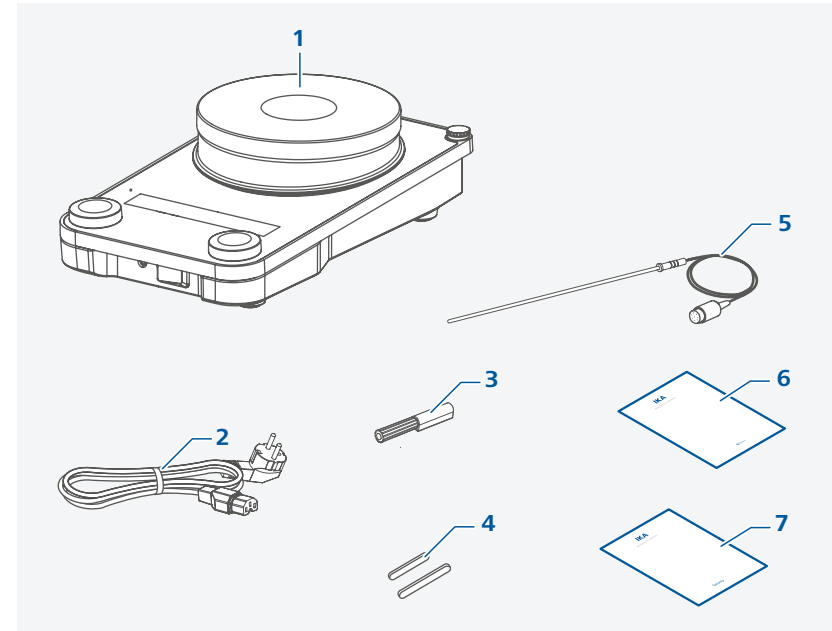

1	RCT basic
2	Power cord set
3	Screwdriver (safety circuit)
4	Magnetic stirring bar <b>IKAFLO</b> N 30 round and <b>IKAFLO</b> N 40 round
5	Temperature sensor <b>PT 1000.60</b>
6	User guide
7	Warranty card



## Installation

/// Assembling support rod / extension etc.

- › Review the mounting and safety instructions of the IKA boss head clamp prior to using it. (see "Accessories")
- › The device must not be suspended from the support rod!

### ⚠ Risk of tipping!

- › Make sure that the center of mass of the attached device does not protrude over the safe area indicated below with a dotted rectangle.

### ⚠ Notice!

- › When using bath attachments with a diameter over 180 mm, use support rod in conjunction with an extension (see "Accessories").

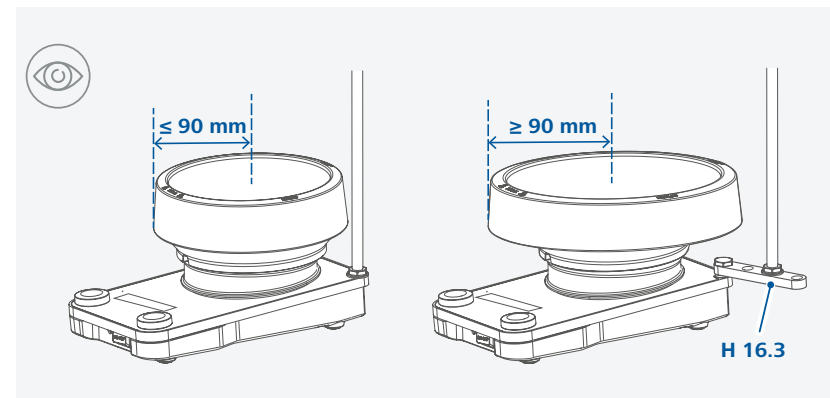
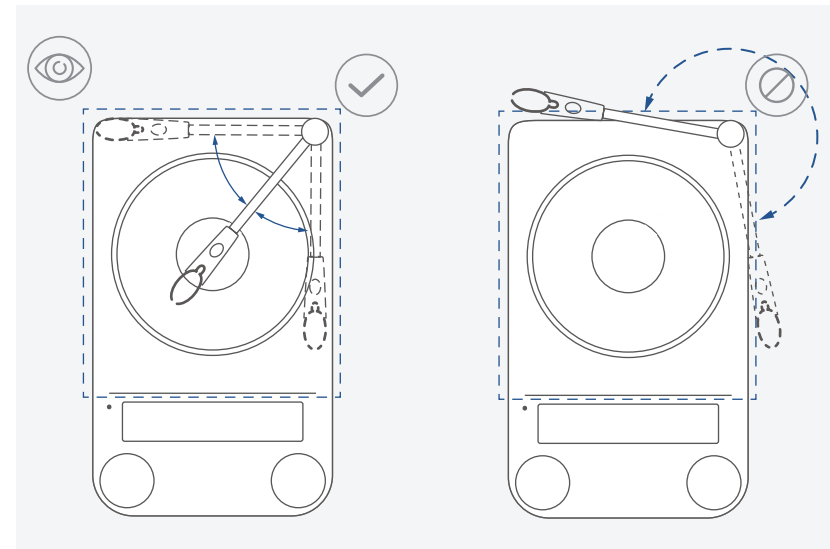
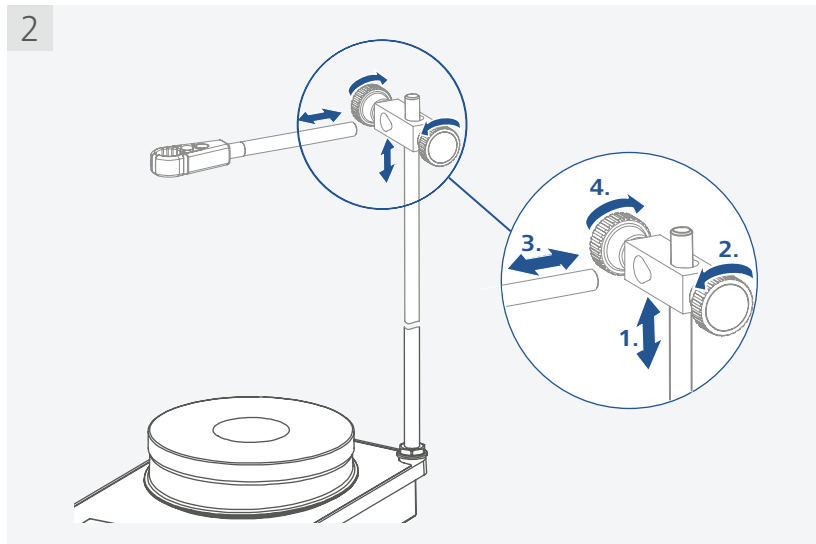
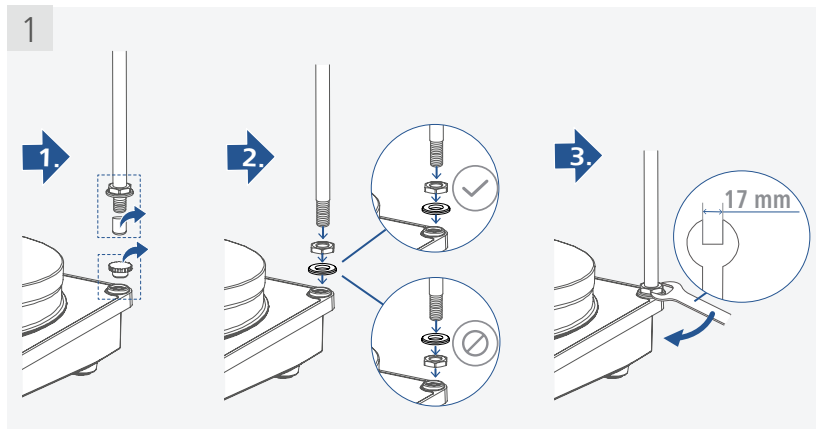

/// Connecting an external temperature sensor / thermometer

1. Switch off the device via the mains switch.
2. Connect the contact thermometers or Temperature sensor PT 1000 (single sensor) to the connection.
3. Switch on the device via the mains switch.

### Temperature sensor PT 1000:

- › The actual temperature value shown on the display corresponds to the temperature of the medium. The temperature sensor LED (🔦) lights.

### Contact thermometer ETS-D5 / ETS-D6:

- › Follow the operating instructions for the contact thermometer. The set temperature value of the heating plate is shown on the display. The LED display (3) lights.

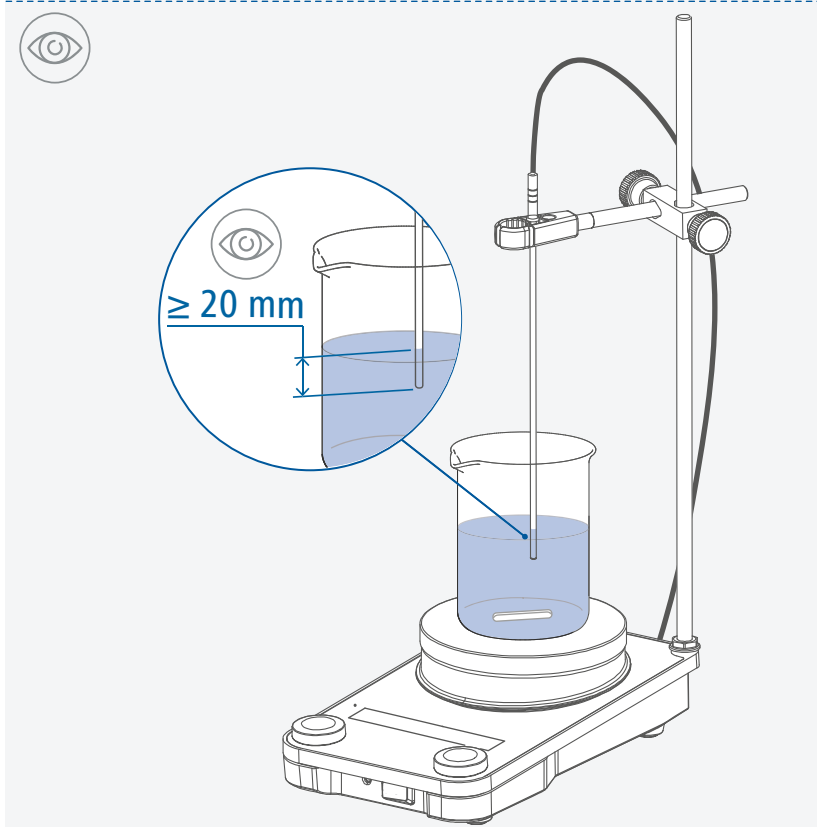
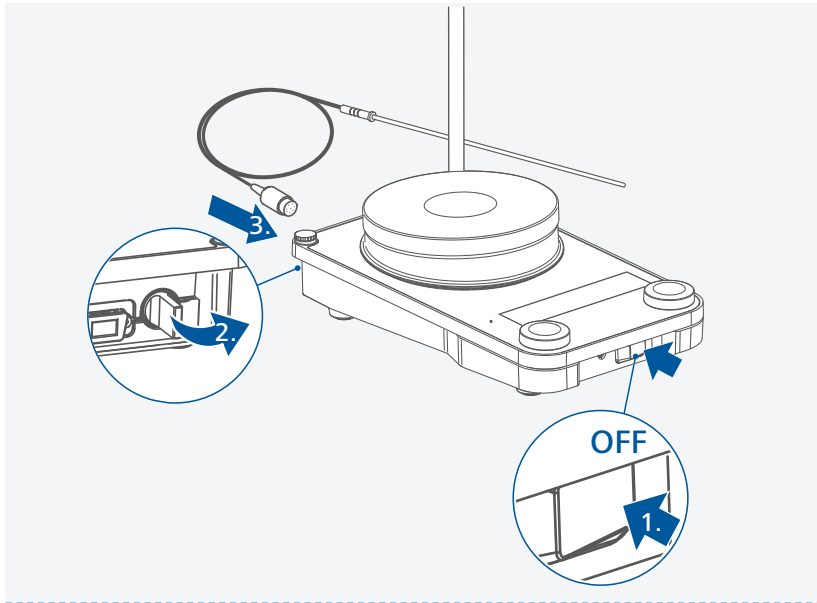

## Operator panel and display

/// Operator panel

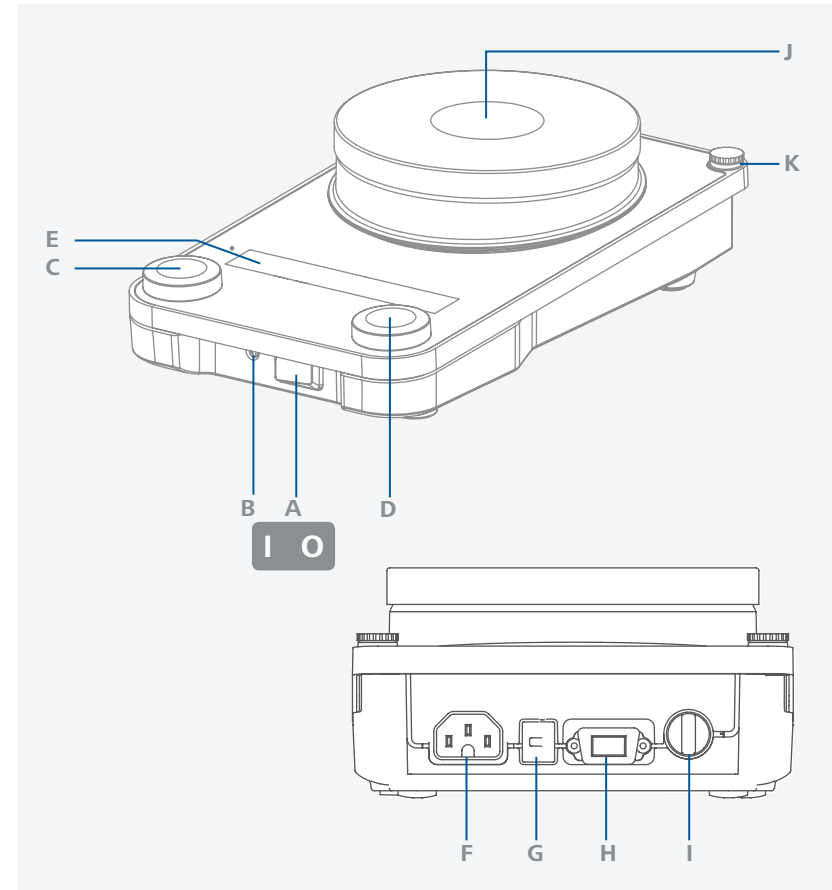

<b>A</b>	Mains switch (left "I" « on, right "O"« off)	<b>G</b>	USB Interface
<b>B</b>	Adjustable safety circuit	<b>H</b>	RS 232 Interface
<b>C</b>	Rotating / pressing knob - Temperature setting	<b>I</b>	Connection for PT 1000 temperature sensor series, temperature probes or contact plugs
<b>D</b>	Rotating / pressing knob - Speed setting	<b>J</b>	Heating plate
<b>E</b>	Display	<b>K</b>	Threaded hole for stand
<b>F</b>	Power socket		

### /// Display

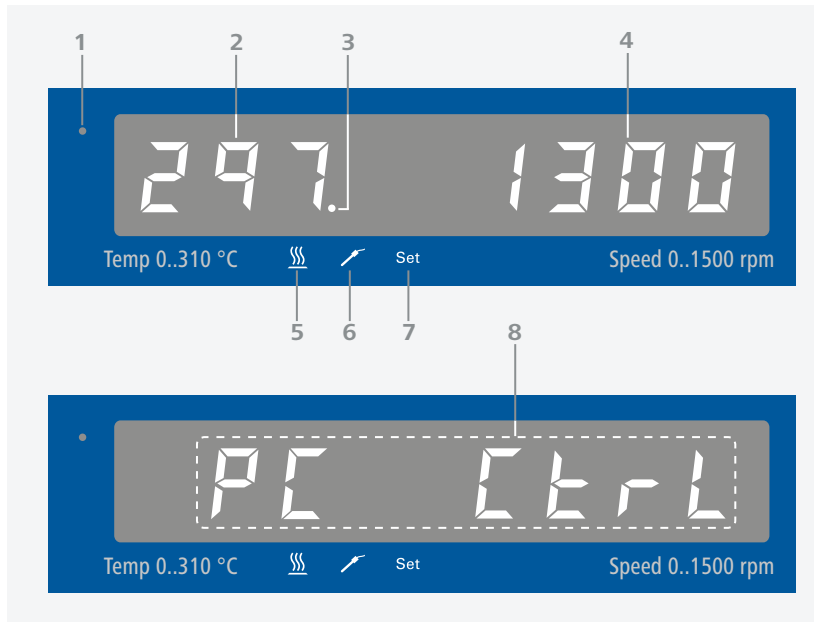

1	Standby LED	5	LED display heating active
2	Temperature display	6	LED display temperature sensor plugged in
3	LED display external contact thermometer plugged in	7	LED display "Set temperature"
4	Speed display	8	PC control display

### Operation

#### /// Switch on

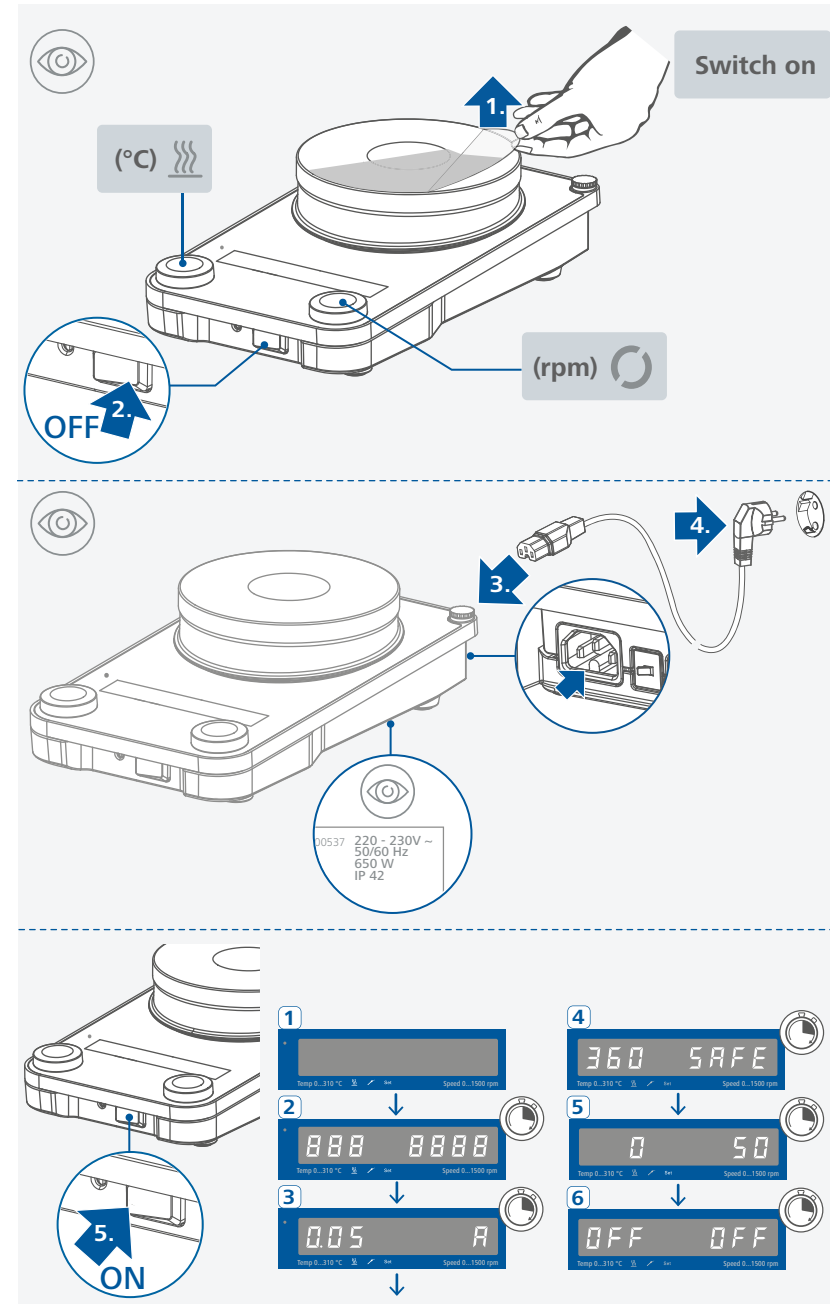

### /// Stirring

- › Set the speed using the rotating / pressing knob (D).  
The set speed value is shown on the right of the display.
- › Press the rotating / pressing knob (D) to start the stirring function.  
The speed value blinks until reaching the set value.

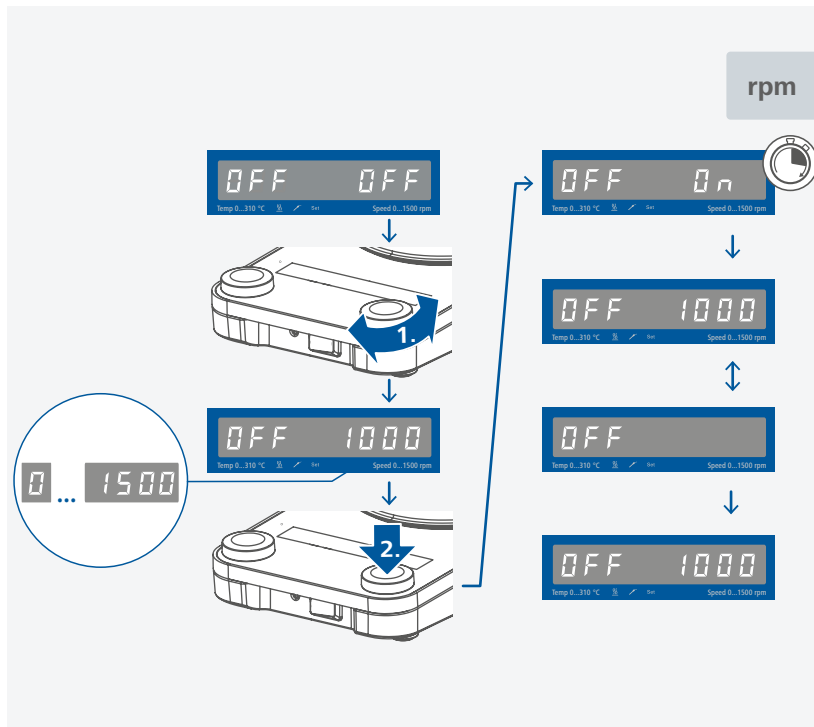

### /// Heating

#### Setting the safety temperature limit:

The maximum achievable heating plate temperature is restricted by an adjustable safety temperature limit. Once this limit has been reached, the device stops heating.

#### ⚠ Notice!

The denominated temperatures should always refer to the center of the heating plate.

#### ⚠ Warning!

The safety temperature limit must always be set at least 25 °C lower than the flash point of the media to be processed!

The adjustable maximum heating plate temperature must always be set at least 15 °C under the set safety temperature limit.

Setting range: see section "Technical data".

After switching on the device, the safety temperature limit can be adjusted using a screwdriver. Do not turn the setting screw beyond the clockwise or anticlockwise stop. This will cause irreparable damage to the potentiometer.

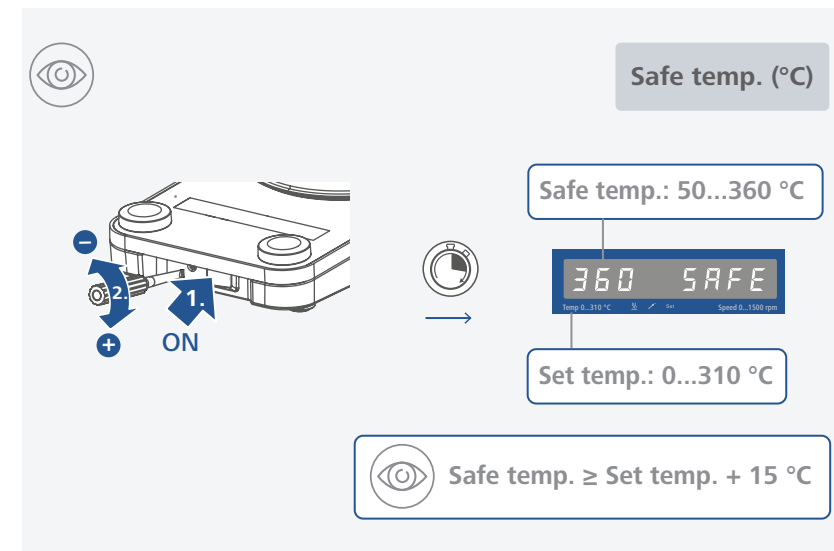

#### Start heating:

- › Set the safety temperature limit. (see "Setting the safety temperature limit")
- › Set the target temperature using the rotating / pressing knob (C).  
The set temperature value is shown on the left of the display.
- › Set the temperature control mode. (see "Temperature control mode")
- › Press the rotating / pressing knob (C) to start the heating function.

#### General information for heating:

- › The set and actual temperature values are shown on the display alternately.
- › When the heating function is switched on, the heating LED indicator "☀" lights.
- › When the device is switched off while the heating plate temperature is higher than 50 °C, the display shows "Hot" and the actual temperature value, even if the device is switched off.

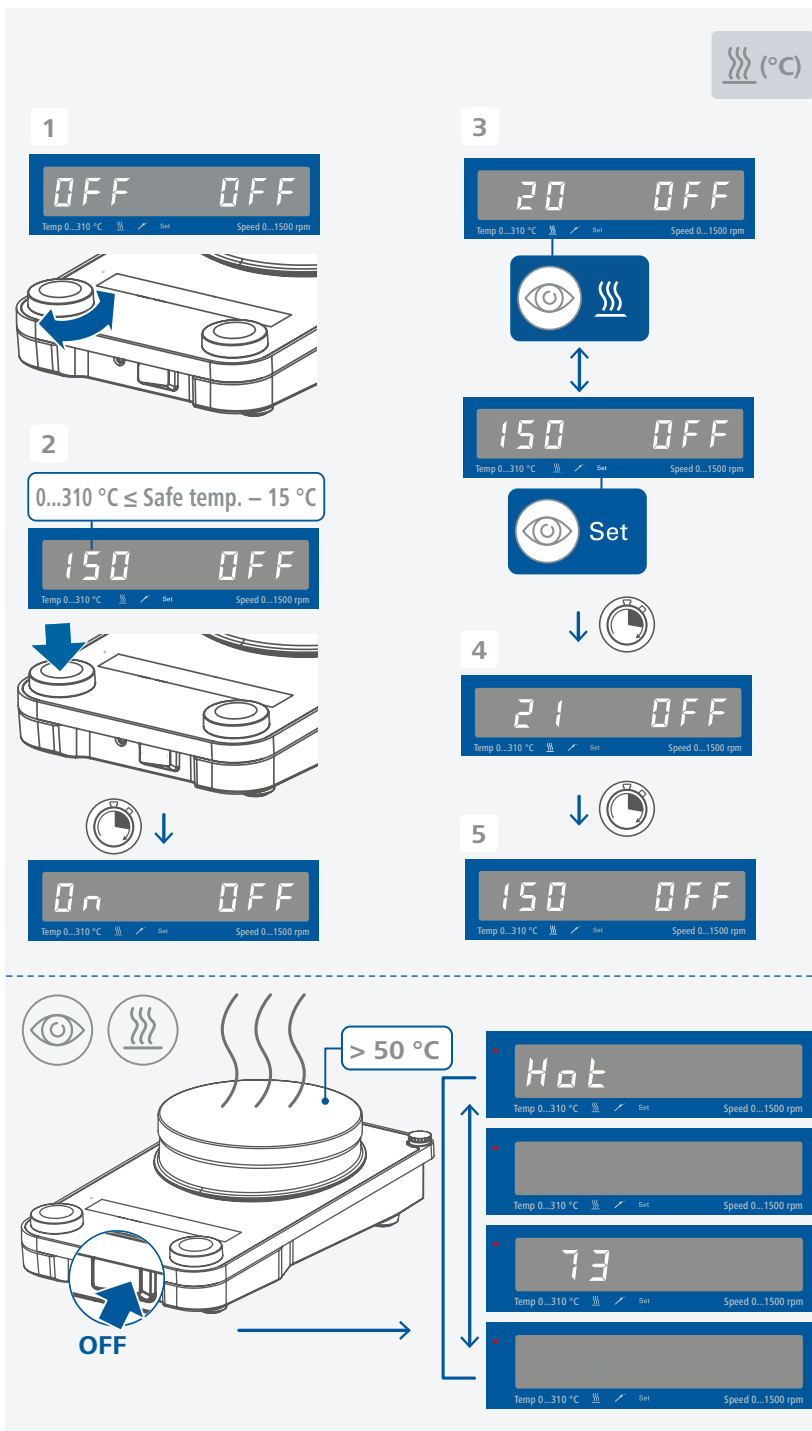

### /// Additional operation

#### Operating mode:

Factory setting: Operating mode A

#### Operating mode A ( A ):

All settings will be stored if the device is switched off or disconnected from the power supply. The heating and stirring functions will be set to OFF when the device is powered on. The safety circuit can be set or modified. When the power supply switch is switched on, " A " is displayed.

#### Operating mode B ( b ):

All settings will be stored if the device is switched off or disconnected from the power supply. The heating and stirring functions will be set to ON or OFF when the device is powered on, depending on the previous status of the device. The safety circuit can be set or modified. When the power supply switch is switched on, " b " is displayed.

#### Operating mode C ( c ):

Set values (set in A or B) cannot be changed. All settings will be stored if the device is switched off or disconnected from the power supply. The heating and stirring functions will be set to ON or OFF when the device is powered on, depending on the previous status of the device. The safety circuit can be set or modified. When the power supply switch is switched on, " c " is displayed.

#### Operating mode D ( d ):

When switching the device on, the safety temperature has to be confirmed by pushing one of the rotating / pressing knobs.

During operation, in operating mode D the device behaves the same as in operating mode A with the exception that:

- > The temperature / speed setting must be confirmed by pressing the rotating / pressing knob. To change the temperature / speed setting, turn the rotating / pressing knob until the desired value appears.
- > The new value flashes for 5 seconds on the display. Confirm the new temperature / speed setting by pressing the rotating / pressing knob. Otherwise, the temperature / speed setting value will skip back to its previous value.

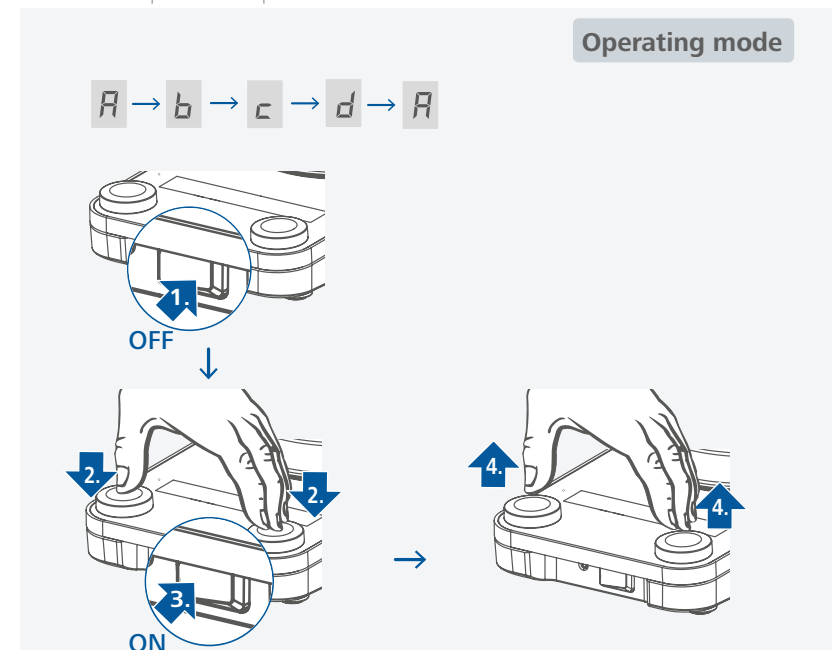

## Temperature control mode:

When using an external PT 1000 temperature sensor, you can choose below control modes.

**Precise control mode (Pr):** **Pr**

Good control results, minimized overshooting, slow rise in temperature.

**Fast control mode (FA):** **FA**

Maximum heating rate, increased overshooting.

Factory setting: Pr mode

### Switching the temperature control mode:

- › Set target temperature to 2 °C by turning the rotating / pressing knob (C).
- › Move the mains switch to the right (OFF) position.
- › Press and hold down the rotating / pressing knob (C)
- › Move the mains switch to the left (ON) position.

If the FA mode is activated and the device is switched on, “FA” is displayed next to the operating mode A/B/D.

When the heating function is active in FA mode, (with external PT 1000 temperature sensor) the actual temperature value displayed flashes!

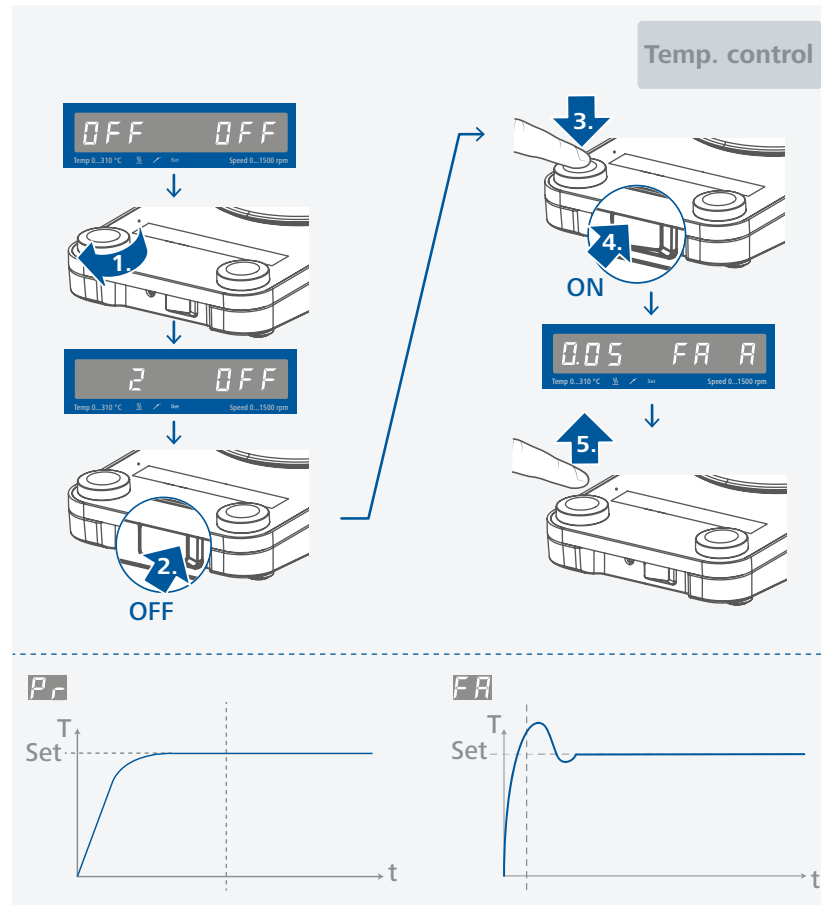

## Error 5:

Providing safety protection, Error 5 is taken to recognize that the sensor has not been placed in the medium when the heating is switched on.

Factory setting: 5 min.

Changing the Error 5 settings:

- › Set target temperature to 5 °C by turning the rotating / pressing knob (C).
- › Move the mains switch to the right (OFF) position.
- › Press and hold on the rotating / pressing knob (C).
- › Move the mains switch to the left (ON) position.
- › Select time value from 0...30 min (in 1 min steps) by turning the rotating / pressing knob (D).
- › Release the rotating / pressing knob (C).

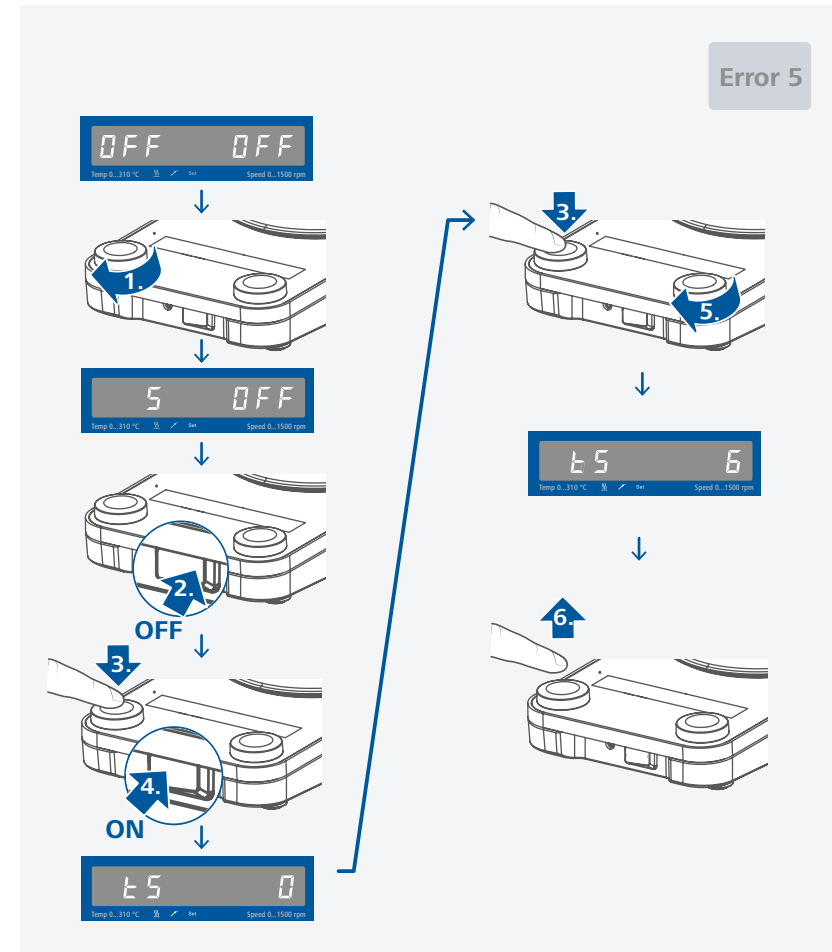

### ⚠ Notice!

You can set a value from 1 to 30 min for this time limit depending on the application. If time limit is set to 0 min, the Error 5 detection is disabled.

### Caution!

This function will only be active if:

- › sensor temperature is < 50 °C
- › difference between target temperature and sensor temperature > 5 K.

The time set will be shown on the display when the device is started up if the sensor is connected.

## /// Controlling the medium temperature limit using a contact thermometer

The preferable method for controlling the average temperature is with contact thermometer. After the set point temperature has been adjusted, this results in a short heating-up time, practically no temperature drift and only minor fluctuation in temperature.

A 6-pin jack is located on the rear side of the device for connecting the PT 1000 series, contact thermometer or the contact plug. The electronics of the devices returns a test current that must flow via connector pins 3 and 5 for the heating plate to heat up.

### Safety function:

If the test current is interrupted because of e.g. breakage of contact thermometer or falling out of the cable plug, the heating cuts off.

### Settings:

For detailed instructions for settings and limit values, please refer to the operating instructions of the device you are connecting.

**The desired medium temperature can be adjusted on the contact thermometer. The required surface temperature of the heating plate can be selected with the rotating / pressing knob or button.**

Adjusting the temperature of device to the maximum adjustable temperature will result in the fastest possible heating time. However, the medium temperature may fluctuate to values above the set-point temperature on the contact thermometer. By adjusting the rotating / pressing knob or button to approximately twice the set-point value of contact thermometer (with a set-point of + 60 °C, the temperature of device would be set to + 120 °C), you will reach a good compromise between a fast heating time and over-shooting the set point. If you adjust the temperature of the device to exactly the set-point temperature, the medium will not reach the set-point temperature because some loss of the heat will always occur between the heating plate and the medium.

**The maximum heating plate temperature is limited to the adjusted safety temperature limit in the event of a control circuit malfunction. (See "Setting the safety temperature limit")**

If the temperature sensor is connected and the temperature value is below -20 °C, three dashes will be shown as the temperature value.

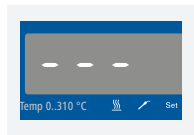

## Interfaces and outputs

The device can be operated by computer via an RS 232 or USB interface using the laboratory software labworldsoft®.

The device software can also be updated with a PC via the RS 232 or USB port.

### Notice!

Please comply with the system requirements together with the operating instructions and help section included with the software.

### /// USB interface:

The connected devices and their properties are detected automatically. The USB interface is used in conjunction with software control for "remote" operation and can also be used for software update of the device.

### /// USB device drivers:

First, download the latest driver for IKA devices with USB interface from:

<http://www.ika.com/ika/lws/download/usb-driver.zip>

Install the driver by running the setup file. Connect the IKA device through the USB data cable to the PC. The data communication runs through a virtual COM port.

**Note:** The USB driver is unnecessary for Windows 10 system. Don't install it for Windows 10 system!

### /// RS 232 interface:

Configuration:

- › The functions of the interface connections between the device and the automation system are chosen from the signals specified in EIA standard RS 232 in accordance with DIN 66 020 Part 1.
- › For the electrical characteristics of the interface and the allocation of signal status, standard RS 232 applies in accordance with DIN 66 259 Part 1.
- › Transmission procedure: asynchronous character transmission in start-stop mode.
- › Type of transmission: full duplex.
- › Character format: character representation in accordance with data format in DIN 66 022 for start-stop mode. 1 start bit; 7 character bits; 1 parity bit (even); 1 stop bit.
- › Transmission speed: 9600 bit/s.
- › Data flow control: none.
- › Access procedure: data transfer from the device to the computer takes place only at the computer's request.

### /// Command syntax and format:

The following applies to the command set:

- › Commands are generally sent from the computer (Leader) to the device (Follower).
- › The device sends only at the computer's request. Even fault indications cannot be sent spontaneously from the device to the computer (automation system).
- › Commands are transmitted in capital letters.
- › Commands and parameters including successive parameters are separated by at least one space (Code: hex 0x20).
- › Each individual command (incl. parameters and data) and each response are terminated with Blank CR LF (Code: hex 0x20 hex 0x0d hex 0x20 hex 0x0A) and have a maximum length of 80 characters.
- › The decimal separator in a number is a dot (Code: hex 0x2E).

The above details correspond as far as possible to the recommendations of the NAMUR working party (NAMUR recommendations for the design of electrical plug connections for analogue and digital signal transmission on individual items of laboratory control equipment, rev. 1.1).

The NAMUR commands and the additional specific IKA commands commissioning serve only as low level commands for communication between the device and the PC. With a suitable terminal or communications program these commands can be transmitted directly to the device. The IKA software package, Labworldsoft®, provides a convenient tool for controlling device and collecting data under MS Windows, and includes graphical entry features, for motor speed ramps for example.

NAMUR Commands	Function
IN_NAME	Read the device name
IN_PV_1	Read actual external sensor value
IN_PV_2	Read actual hotplate sensor value
IN_PV_4	Read stirring speed value
IN_SP_1	Read rated temperature value
IN_SP_3	Read rated set safety temperature value
IN_SP_4	Read rated speed value
OUT_SP_1 xxx	Adjust the set temperature value xxx
OUT_SP_4 xxx	Adjust the set speed value xxx
START_1	Start the heater
STOP_1	Stop the heater
START_4	Start the motor
STOP_4	Stop the motor
RESET	Switch to normal operating mode
SET_MODE_n (n=A, b, or d)	Set operating mode
OUT_SP_12@n	Setting WD safety limit temperature with set value echo
OUT_SP_42@n	Setting WD safety limit speed with set value echo
OUT_WD1@m	Watchdog mode 1: if event WD1 should occur, the heating and stirring functions are switched off and E 2 is displayed. Set watchdog time to m (20 - 1500) seconds, with watchdog time echo. This command launches the watchdog function and must be transmitted within the set watchdog time.
OUT_WD2@m	Watchdog mode 2: if event WD2 should occur, the speed target value is changed to the WD safety speed limit and the temperature target value is changed to the WD safety temperature limit value. The warning WD is displayed. The WD2 event can be reset with OUT_WD2@0 - this also stops the watchdog function. Set watchdog time to m (20 - 1500) seconds, with watchdog time echo. This command launches the watchdog function and must be transmitted within the set watchdog time.

### “Watchdog” functions, monitoring of the serial data flow:

If, once this function has been activated (see NAMUR commands), there is no retransmission of the command from the computer within the set time (“watchdog time”), the heating and stirring functions are switched off in accordance with the set “watchdog” function or are changed to the set target values.

The data transmission may be interrupted by, for example, a crash in the operating system, a power failure in the PC or an issue with the connection cable between the computer and the device.

#### “Watchdog” – mode 1:

If there is an interruption in data communications (longer than the set watchdog time), the heating and stirring functions are switched off and E 2 is displayed.

#### “Watchdog” – mode 2:

If there is an interruption in data communications (longer than the set watchdog time), the speed target value is changed to the WD safety speed limit and the temperature target value is changed to the WD safety temperature limit value. The warning WD is displayed.

## /// Connections between device and external devices

### PC 1.1 cable:

This cable is required to connect RS 232 port to a PC.

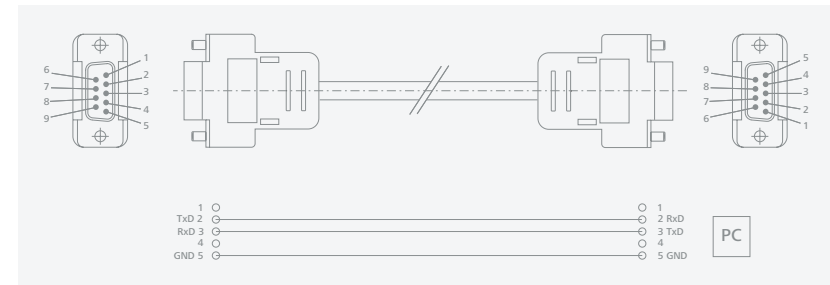

### USB cable A – B:

This cable is required to connect USB port to a PC.

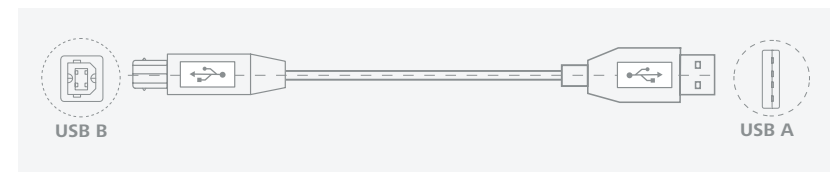

## Maintenance and cleaning

- › The device is maintenance-free. It is only subject to the natural wear and tear of components and their statistical failure rate.

### /// Cleaning:

- › For cleaning disconnect the mains plug!
- › Use only cleaning agents which have been approved by IKA to clean the devices:  
Water containing surfactant / isopropyl alcohol.
- › Wear protective gloves during cleaning the devices.
- › Electrical devices may not be placed in the cleansing agent for the purpose of cleaning.
- › Do not allow moisture to get into the device when cleaning.
- › Before using another than the recommended method for cleaning or decontamination, the user must ascertain with IKA that this method does not destroy the device.

### /// Spare parts order:

- › When ordering spare parts, please give:
  - device type.
  - serial number, see type plate.
  - position number and description of spare part, see [www.ika.com](http://www.ika.com).
  - software version.

### /// Repair:

- › Please only send devices in for repair that have been cleaned and are free of materials which might present health hazards.
- › For repair, please request the “**Safety Declaration (Decontamination Certificate)**” from IKA or use the downloaded printout of it from IKA website at [www.ika.com](http://www.ika.com).
- › If your appliance requires repair, return it in its original packaging. Storage packaging is not sufficient when sending the device - also use appropriate transport packaging.

## Accessories

- › For accessories see [www.ika.com](http://www.ika.com).

## Error codes

- › The fault is shown by an error code on the display as following if the error occurs. Proceed as follows in such cases:
  - Turn off the device by using the mains switch (left « “ON”, right « “OFF”).
  - Carry out corrective measures.
  - Restart the device.

### Error code | Causes | Effect | Solutions

#### E 2 - Watchdog error

Causes	› PC does not transmit any data within the set watchdog time › connection to PC interrupted
Effect	› heating switched off › motor switched off
Solutions	› change watchdog time › transmit data from PC within set watchdog time (OUT_WDx@m) › check cable and plug

#### E 3 - Temperature in the device is higher than 80 °C

Causes	› heat accumulation between heating plate and housing › permitted ambient temperature exceeded
Effect	› heating switched off
Solutions	› switch device off, leave to cool and switch on again › change experiment › observe maximum permissible ambient temperature

#### E 4 - Motor control is unavailable

Causes	› motor blocked or overloaded
Effect	› heating switched off › motor switched off
Solutions	› reduce load torque or use smaller magnetic rods › reduce target speed

#### E 5 - No temperature increase measured by temperature sensor (in the set time for t5)

Causes	› sensor not in medium › volume of medium to be measured too large › heat conductivity of medium to be measured too low › heat conductivity of the vessel is too low › in the case of indirect heating, the overall heat conductivity resistance is too large
Effect	› heating switched off
Solutions	› place the sensor in the medium › reduce the volume of the media › use a carrier fluid with better heat conductivity properties › replace the glass vessel with a metal pot › increase the “Time-out” period

### E 6 - Interruption of the safety circuit

Causes	› break in safety circuit
Effect	› heating switched off
Solutions	› plug in contact plug › plug in PT 1000 temperature sensor › replace faulty connecting cable, plug, or contact thermometer

### E 13 - Hotplate safety sensor, open-circuit

Causes	› target / current different of the adjustable safety circuit for minimum temperature monitoring
Effect	› heating switched off
Solutions	› after switching on, change the SAFE TEMP to a different value; if this solves the issue, the previous value can be reset by switching the device off and on again

### E 14 - External temperature sensor, short-circuit

Causes	› short circuit in temperature sensor plug › short circuit in the cable or temperature sensor
Effect	› heating switched off
Solutions	› check the plug › replace the temperature sensor

### E 21 - Fault during heating plate safety test

Causes	› safety relay does not open
Effect	› heating switched off
Solutions	› switch device off, leave to cool and switch on again

### E 22 - Fault during heating plate safety test

Causes	› S_CHECK cannot generate H_S_TEMP
Effect	› heating switched off
Solutions	› switch device off, leave to cool and switch on again

### E 24 - Heating plate temperature is higher than the set safety temperature

Causes	› safety temperature has been set to lower than the current temperature of the heating plate › disconnection of heating plate control temperature sensor
Effect	› heating switched off
Solutions	› leave the heating plate to cool › set the safety temperature higher

### E 25 - Heating switching element monitoring fail

Causes	› heater control circuit switch (TRIAC) short-circuited › safety relay has interrupted the heating circuit › heater or the supply line is disconnected › disconnection of heating plate safety temperature sensor
Effect	› heating switched off
Solutions	› switch device off, leave to cool and switch on again

### E 26 – Plate temperature > plate safety temperature (more than 40 K)

Causes	› irregular temperature distribution across heating plate due to sporadic heat dissipation › defective control or safety temperature sensor
Effect	› heating switched off
Solutions	› switch device off, leave to cool and switch on again › ensure regular heat dissipation when using metal blocks, etc. on the flat surface of the heating plate

### E 31 – Fault in the heater switch element

Effect	› heating switched off
Solutions	› contact customer service

### E 44 – Heating plate safety temperature is higher than the set safety temperature

Causes	› the set safety temperature has been set to lower than the safety temperature of the heating plate › disconnection of heating plate safety temperature sensor
Effect	› heating switched off
Solutions	› leave the heating plate to cool › set the safety temperature higher

### E 46 – Plate safety temperature > plate temperature (more than 40 K)

Causes	› irregular temperature distribution across heating plate due to sporadic heat dissipation › defective control or safety temperature sensor
Effect	› heating switched off
Solutions	› switch device off, leave to cool and switch on again › ensure regular heat dissipation when using metal blocks, etc. on the flat surface of the heating plate

- › If the actions described fails to resolve the fault or another error code is displayed then take one of the following steps:
  - contact the service department.
  - send the device for repair, including a short description of the fault.



## Technical data

General data	
Voltage	220 ... 230 VAC ± 10 % 115 VAC ± 10 % 100 VAC ± 10 %
Frequency	50 / 60 Hz
Power input	650 W
Power input standby	1.6 W
Self-heating of the heating plate by max. stirring (RT: 22 °C / duration:1 h)	+ 13 K
Interface	USB, RS 232
Permissible ambient temperature	+ 5 ... + 40 °C
Permissible relative humidity	80 %
Protection class according to DIN EN 60529	IP 42
Protection class	I
Contamination level	2
Overvoltage category	II
Plate material	Aluminium
Plate dimensions	Ø 135 mm
Dimensions (W × D × H)	160 × 270 × 85 mm
Weight	2.4 kg
Operation at a terrestrial altitude	max. 2000 m
Stirring function	
Number of stirring positions	1
Motor rating output	9 W
Direction of rotation	right
Max. stirring quantity (H <sub>2</sub> O)	20 l
Speed range	0 / 50 ... 1500 rpm
Speed display	LED
Speed setting	rotating / pressing knob
Speed setting accuracy	10 rpm
Speed variation (no load, nominal voltage, at 1500 rpm, ambient temperature +25 °C)	± 2 %
Stirring bar length	20 ... 80 mm

Heating function	
Heat output	600 W
Heating temperature range	RT + device self-heating ... 310 °C
Temperature setting range	0 ... 310 °C
Temperature display	LED
Temperature setting	rotating / pressing knob
Temperature setting resolution of heating plate	1 K
Temperature setting resolution of medium	1 K
Heating rate (1 l water in H 1500)	6.5 K / min
Temperature control accuracy of heating plate (at 100 °C)	± 5 K
Adjustable safety circuit	(50 °C ... 360 °C) ± 10 °C
External temperature sensor / thermometer	
Connection for external temperature sensor / thermometer	PT 1000 series (excluding double PT 1000 sensors), ETS-D5, ETS-D6
Temperature control accuracy (500 ml water in 600 ml glass beaker, 40 mm bar, 600 rpm, 50 °C)	± 1.0 K ( with temperature sensor PT 1000) ± 0.5 K (with thermometer ETS-D5) ± 0.2 K (with thermometer ETS-D6)
Temperature measuring range PT 1000	-10 °C ... + 350 °C
Temperature sensor PT 1000 deviation EN 60751 class A	≤ ± (0.15 + 0.002 × ITI)
Temperature measurement accuracy	± 0.5 + tolerance PT 1000 (DIN EN 60751 class A)
Sensor in medium detection (Error 5)	yes

*Subject to technical changes!*

## Warranty

- › In accordance with IKA warranty conditions, the warranty period is 24 months. For claims under the warranty please contact your local dealer. You may also send the device direct to our factory, enclosing the delivery invoice and giving reasons for the claim. You will be liable for freight costs.
- › The warranty does not cover worn out parts, nor does it apply to faults resulting from improper use, insufficient care or maintenance not carried out in accordance with the instructions in this operating instructions.



# WolfLabs

**Pricing on any accessories shown can be found by keying the part number into the search box on our website.**

The specifications listed in this brochure are subject to change by the manufacturer and therefore cannot be guaranteed to be correct. If there are aspects of the specification that must be guaranteed, please provide these to our sales team so that details can be confirmed.

**[www.wolflabs.co.uk](http://www.wolflabs.co.uk)**

**Tel : 01759 301142**

**Fax : 01759 301143**

**[sales@wolflabs.co.uk](mailto:sales@wolflabs.co.uk)**

Please contact us if this literature doesn't answer all your questions.