

FLOORSTANDING CENTRIFUGES

— ROTO SILENTA 630 RS

YOUR FIRST CHOICE UP TO 12 LITERS

The ROTO SILENTA 630 RS is highly rated in the rapid and efficient centrifugation of blood bags. It is able to spin up to 12 liters of sample or 12 blood bags per run. Four and six-place rotor options are also available to offer the best possible fit.

In industrial or R&D settings the ROTO SILENTA accommodates six vessels up to 2,000 ml each.

This unit includes refrigeration with a temperature range from -20°C to +40°C.



— HIGHLIGHTS

- RPM: 50 - 6,000 min⁻¹
Adjustable in increments of 10
- RCF: 50 - 6,520
Adjustable in increments of 1
- max. Capacity: 6 x 2,000 ml
- the first choice in blood banking centrifuges
- Choice of 3 rotors
- Registered Medical Device
- easy operation with keypad and control knob
- 89 program memories for more individuality
- 9 acceleration + 19 deceleration stages
- coolable from -20 bis +40 °C with pre-cooling function
- data reporting system (optional)

— FEATURES

- metal housing and lid
- large viewing port in the lid
- powered lid lock
- lid dropping protection
- emergency lid lock release
- stainless steel chamber
- automatic rotor recognition
- brushless drive
- error display
- display in °C and °F possible
- imbalance detection and switch-off

TECHNICAL DATA

ROTO SILENTA 630 RS ^{>)} refrigerated

voltage ^{*)}	400 V 3 ~ + N
frequency	50 – 60 Hz
consumption	9,700 VA
emission, immunity	EN/IEC 61326-1, class B
max. capacity	6 x 2,000 ml
max. RPM	6,000 min ⁻¹
max. RCF	6,520
running time	1 – 999 min: 59 s, ∞ continuous run
dimensions (WxDxH)	813 x 1,015 x 973 mm
weight	approx. 355 kg
temperature control, infinitely variable	from -20 to +40 °C
Cat. No.	5005

208 – 220 V +6 / -10 % 3- (+N) + PE,
with internal transformer



consumption	9,000 VA
weight	approx. 401 kg

^{*)} Other voltages on request.

^{>)} Other models on request.

AVAILABLE ROTORS

SWING-OUT ROTORS

	angle	max. RPM	max. capacity	Cat. No.	page
 swing-out rotor, 6-place	90°	4,500 min ⁻¹	6 x 2,000 ml	4176	3
 swing-out rotor, 4-place	90°	4,500 min ⁻¹	4 x 1,600 ml	4174	3

ANGLE ROTORS

 angle rotor, 6-place	25°	6,000 min ⁻¹	6 x 250 ml	4570	9
--	-----	-------------------------	------------	-------------	---

— SWING-OUT ROTOR, 6- / 4-PLACE | 4176 / 4174



Rotor	
max. RPM	4,500 min ⁻¹
max. RCF Rotor 4176 / 4174	6,498 / 5,683
max. capacity	12 / 8 blood bag
run-up run-down, braked in sec	125 197
angle temperature in °C ¹⁾	90° +16 / +10
Cat. No.	4176 / 4174

Bucket	
Cat. No.	4524-A

Blood bag				
capacity in ml		500	500	750
blood bag per system		4-place	4-place	1-place
max. RCF ²⁶⁾ Rotor 4176 / 4174		6,498 / 5,683	6,498 / 5,683	6,498 / 5,683
radius in mm		287 / 251	287 / 251	287 / 251
Cat. No.		-	-	-

Insert				
boring Ø x L in mm		-	-	-
blood bag systems per rotor		12 / 8	12 / 8	12 / 8
Cat. No.		4529²⁶⁾-AO,-AM,-AU	4592-B	4592-B

+ Additional blood bank accessories can be found on [page 185](#)

— SWING-OUT ROTOR, 6- / 4-PLACE | 4176 / 4174



Rotor	
max. RPM	4,500 min ⁻¹
max. RCF Rotor 4176 / 4174	6,271 / 5,479
max. capacity	12 / 8 blood bag
run-up run-down, braked in sec	125 197
angle temperature in °C ¹⁾	90° +10 / 0
Cat. No.	4176 / 4174

Bucket	
Cat. No.	4546-A

Blood bag		
capacity in ml		450
blood bag per system		4-place
max. RCF Rotor 4176 / 4174		6,271 / 5,479
radius in mm		277 / 242
Cat. No.		-

Insert		
boring Ø x L in mm		-
blood bag systems per rotor		12 / 8
Cat. No.		4559-A

+ Additional blood bank accessories can be found on [page 185](#)

- 1) For cooled versions: Lowest temperature achievable with precooling and max. speed.
- 26) Includes blood bag hanging to prevent erythrocyte accumulation at low speeds. Different hanging heights allow customer-specific adjustments. (4529-AO top, 4529-AM center, 4529-AU bottom). Hanging blood bags may be centrifuged with a maximum RCF of 1,000.

— SWING-OUT ROTOR, 6- / 4-PLACE | 4176 / 4174

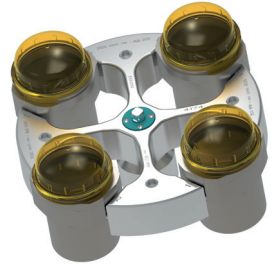

Rotor		+	Bucket	
max. RPM	4,500 min ⁻¹		Cat. No.	4591-A
max. RCF	Rotor 4176 / 4174 6,498 / 5,705			
max. capacity	12 / 8 blood bag			
run-up run-down, braked in sec	125 197			
angle temperature in °C ¹⁾	90° +16 / +10			
Cat. No.	4176 / 4174			

Blood bags			
capacity in ml	450	500	750
blood bag per system	3-place	4-place	1-place
max. RCF	Rotor 4176 / 4174 6,271 / 5,705	6,498 / 5,705	6,498 / 5,705
radius in mm	287 / 252	287 / 251	287 / 251
Cat. No.	-	-	-

Insert			
boring Ø x L in mm	-	-	-
blood bag systems per rotor	12 / 8	12 / 8	12 / 8
Cat. No.	4598-A	4592-B	4592-B

+ Additional blood bank accessories can be found on [page 185](#)

— SWING-OUT ROTOR, 6- / 4-PLACE | 4176 / 4174



Rotor		+	Bucket	
max. RPM	3,500 min ⁻¹		Cat. No.	4595-C ³¹⁾
max. RCF	Rotor 4176 / 4174 3,848 / 3,328			
max. capacity	6 x 2,000 ml			
angle temperature in °C ¹⁾	90° +16 / -12			
Cat. No.	4176 / 4174			

Vessels		
capacity in ml	max. 1,600 ³⁵⁾	2,000
W x D x H in mm	-	150 x 100 x 180
max. RCF	Rotor 4176 / 4174 3,821 / 3,328	3,848 / -
radius in mm	279 / 243	281 / -
run-up, in sec	95 / 131	95 / -
run-down, braked in sec	131 / 131	41 / -
Cat. No.	-	0550 ²⁴⁾

Insert		
W x D x H in mm	145 x 91 x 146	-
vessels per rotor	6 / 4	6 / -
Cat. No.	4596-A	-

- 1) For cooled versions: Lowest temperature achievable with precooling and max. speed.
- 24) At temperatures of over +40 °C and / or when not filled to capacity, bottles may warp during centrifugation.
- 31) Adapter for accommodating sample tubes and blood collection tubes in carrier 4595-C on request.
- 35) Depending on the sample.

— SWING-OUT ROTOR, 6- / 4-PLACE | 4176 / 4174



Rotor	
max. RPM	4,500 min ⁻¹
max. RCF Rotor 4176 / 4174	6,520 / 5,705
max. capacity	6 / 4 blood bag
run-up run-down, braked in sec	125 197
angle temperature in °C ¹⁾	90° +9 / +3
Cat. No.	4176 / 4174

Bucket	
Cat. No.	4523-A

Blood bags			
capacity in ml	500	750	1,000
blood bag per system	4-place	1-place	1-place
max. RCF Rotor 4176 / 4174	6,475 / 5,660	6,475 / 5,660	6,520 / 5,705
radius in mm	285 / 250	285 / 250	288 / 252
Cat. No.	-	-	-

Insert			
boring Ø x L in mm	-	-	-
blood bag systems per rotor	6 / 4	6 / 4	6 / 4
Cat. No.	4516-A	4516-A	-

+ Additional blood bank accessories can be found on [page 185](#)

— SWING-OUT ROTOR, 6- / 4-PLACE | 4176 / 4174

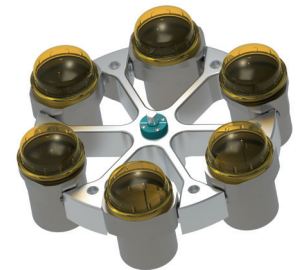
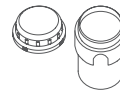
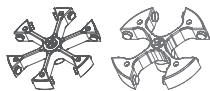

Rotor	
max. RPM	4,500 min ⁻¹
max. RCF Rotor 4176 / 4174	6,316 / 5,524
max. capacity	6 / 4 blood bag
run-up run-down, braked in sec	125 197
angle temperature in °C ¹⁾	90° +9 / -9
Cat. No.	4176 / 4174

Bucket	
lid	5621
Cat. No.	4547-B

Blood bags		
capacity in ml	500	450
blood bag per system	4-place	3-place
max. RCF Rotor 4176 / 4174	6,316 / 5,524	6,316 / 5,524
radius in mm	279 / 244	279 / 244
Cat. No.	-	-

Insert		
boring Ø x L in mm	-	-
blood bag systems per rotor	6 / 4	6 / 4
Cat. No.	4548	4548

+ Additional blood bank accessories can be found on [page 185](#)

1) For cooled versions: Lowest temperature achievable with precooling and max. speed.

SWING-OUT ROTOR, 6- / 4-PLACE | 4176 / 4174



Rotor	
max. RPM	4,500 min ⁻¹
max. RCF	Rotor 4176 / 4174 6,294 / 5,501
max. capacity	6/4 x 1,000 ml
run-up run-down, braked in sec	125 197
angle temperature in °C ¹⁾	90° +4 / -11
Cat. No.	4176 / 4174



Bucket	
adapter including lid	4255
Cat. No.	4579-A

Vessels	
capacity in ml	5 7 9 15 25 50 100 2.6-3.4 2.7-3 4-5.5 4.5-5 4.9 9-10 10 1.6-5
Ø x L in mm	12x75 12x100 14x100 17x100 24x100 34x100 44x100 13 x 65 11 x 66 15x75 11 x 92 13x90 16x92 15x102 13x75
max. RCF ²⁾	Rotor 4176 / 4174 5,750 / 4,935 5,750 / 4,935 5,886 / 5,094 5,886 / 5,094 5,615 / 4,845 5,705 / 4,890 5,683 / 4,867 5,750 / 4,935 5,750 / 4,935 5,886 / 5,094 5,750 / 4,935 5,750 / 4,935 5,886 / 5,094 5,886 / 5,094 5,750 / 4,935
radius in mm	254 / 218 254 / 218 260 / 225 260 / 225 248 / 214 252 / 216 251 / 215 254 / 218 254 / 218 260 / 225 254 / 218 254 / 218 260 / 225 260 / 225 254 / 218
Cat. No.	tubes²⁾ blood collection / urine tubes

Adapter	
boring Ø x L in mm	13 x 58 13 x 58 17,5 x 60 17,5 x 60 26 x 72 36 x 79 45 x 78 13,5 x 58 13 x 58 17,5 x 60 13 x 58 13,5 x 58 17,5 x 60 17,5 x 60 13,5 x 58
vessels per rotor	180 / 120 180 / 120 114 / 76 114 / 76 42 / 28 24 / 16 12 / 8 126 / 84 180 / 120 114 / 76 180 / 120 126 / 84 114 / 76 114 / 76 126 / 84
Cat. No.	4433 4433 4434 4434 4438 4439 4442 4435 4433 4434 4433 4435 4434 4434 4435

Vessels	
capacity in ml	4-7 4-7 8.5-10 15 50 25 30 10 250 290 650 ^{3.15)} 750 ^{3.15)} 1,000 ^{3.15)} 1,000 175 ^{3.15)}
Ø x L in mm	13x100 16x75 16x100 17x120 29x115 25x90 25 x 110 16 x 80 61 x 122 62 x 137 97 x 139 97 x 152 96 x 176 98 x 138 61 x 118
max. RCF ²⁾	Rotor 4176 / 4174 5,750 / 4,935 5,886 / 5,094 5,886 / 5,094 6,022 / 5,207 5,999 / 5,207 5,818 / 5,026 5,818 / 5,026 5,886 / 5,094 6,113 / 5,320 6,113 / 5,320 5,999 / 5,184 6,294 / 5,501 6,294 / 5,501 6,294 / 5,501 6,294 / 5,501
radius in mm	254 / 218 260 / 225 260 / 225 266 / 230 265 / 230 257 / 222 257 / 222 260 / 225 270 / 235 270 / 235 265 / 229 278 / 243 278 / 243 278 / 243 278 / 243
Cat. No.	blood collection / urine tubes tubes with screw cap 5127²⁴⁾ -²⁴⁾ 0554²⁴⁾ 0512²⁴⁾ 4239²⁴⁾ 4255 Falcon

Adapter	
boring Ø x L in mm	13,5 x 58 17,5 x 60 17,5 x 60 17 x 86 30 x 87 26 x 72 26 x 72 17,5 x 60 62 x 92 62 x 92 98 x 138 98 x 138 98 x 138 - 61 x 118
vessels per rotor	126 / 84 114 / 76 114 / 76 72 / 48 30 / 20 42 / 28 42 / 28 114 / 76 6 / 4 6 / 4 6 / 4 6 / 4 6 / 4 6 / 4 6 / 4
Cat. No.	4435 4434 4434 4437 4441 4438 4438 4434 4443 4443 4258 - - - 4440

Vessels	
capacity in ml	175 200 225 250 500
Ø x L in mm	61.5x144 60 x 130 61 x 137 60 x 162 96 x 147
max. RCF ²⁾	Rotor 4176 / 4174 6,294 / 5,501 6,294 / 5,501 6,294 / 5,501 6,294 / 5,501 6,294 / 5,501
radius in mm	278 / 243 278 / 243 278 / 243 278 / 243 278 / 243
Cat. No.	Nalgene® Nunc® Falcon® Corning® Corning®

Adapter	
boring Ø x L in mm	- - - - -
vessels per rotor	6 / 4 6 / 4 6 / 4 6 / 4 6 / 4
Cat. No.	4430 4430 4440 4430 4449

- 1) For cooled versions: Lowest temperature achievable with precooling and max. speed.
- 2) Please note that the RCF values indicated refer only to rotor performance. The max. permissible RCF of tubes used should be verified with the individual manufacturers.
The max. RCF for glass tubes annotated with footnote 2) is 4,000.
- 3.15) When using these tubes, carrier 4255 cannot be closed with its lid.
- 24) At temperatures of over +40 °C and / or when not filled to capacity, bottles may warp during centrifugation.

— SWING-OUT ROTOR, 6- / 4-PLACE | 4176 / 4174

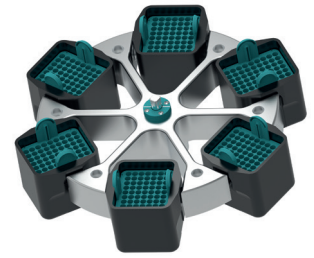

Rotor	
max. RPM	4,500 min ⁻¹
max. RCF Rotor 4176 / 4174	5,999 / 5,184
max. capacity	6x750 ml
run-up run-down, braked in sec	125 197
angle temperature in °C ¹⁾	90° +14 / -1
Cat. No.	4176 / 4174

Bucket	
Cat. No.	4522-A

Vessels															
capacity in ml	4	5	6	7	12	15	25	50	100	2.6-3.4	2.7-3	4-5.5	4.5-5	7.5-8.5	9-10
Ø x L in mm	10x88	12x75	12x82	12x100	16x101	17x100	24x100	34x100	44x115	13x65	11x66	15x75	11x92	15x92	16x92
max. RCF Rotor 4176 / 4174	5,818 / 5,003	5,818 / 5,003	5,818 / 5,003	5,818 / 5,003	5,818 / 5,003	5,818 / 5,003	5,818 / 5,003	5,818 / 5,003	5,818 / 5,003	5,818 / 5,003	5,818 / 5,003	5,818 / 5,003	5,818 / 5,003	5,818 / 5,003	5,818 / 5,003
radius in mm	257 / 221	257 / 221	257 / 221	257 / 221	257 / 221	257 / 221	257 / 221	257 / 221	257 / 221	257 / 221	257 / 221	257 / 221	257 / 221	257 / 221	257 / 221
Cat. No.	tubes²⁾								blood collection / urine tubes						

Adapter															
boring Ø x L in mm	11 x 70	12.5 x 32	12.5 x 70	12.5 x 70	16x70	17.5x70	26x70	35x70	41.5x70	13.2x32	12.5x32	17.5x32	12.5 x 70	17.5 x 70	17.5 x 70
vessels per rotor	378 / 252	288 / 192	288 / 192	288 / 192	150 / 100	180 / 120	66 / 44	36 / 24	24 / 16	180 / 120	288 / 192	180 / 120	288 / 192	180 / 120	96 / 64
Cat. No.	4224	4213-93	4213	4213	4223	4214	4215	4216	4218	4222-93	4213-93	4214-93	4213	4214	4220

Vessels															
capacity in ml	10	1.6-5	4-7	4-7	8	8.5-10	15	50	12	30	50	250	290	600	650
Ø x L in mm	15x102	13x75	16x75	13x100	16x125	16x100	17x120	29x115	17 x 100	25 x 110	29x115	61 x122	62 x 137	93x134	97 x 139
max. RCF Rotor 4176 / 4174	5,818 / 5,003	5,818 / 5,003	5,818 / 5,003	5,818 / 5,003	5,818 / 5,003	5,818 / 5,003	5,999 / 5,184	5,999 / 5,184	5,818 / 5,003	5,818 / 5,003	5,909 / 5,094	5,818 / 5,003	5,818 / 5,003	5,999 / 5,184	5,999 / 5,184
radius in mm	257 / 221	257 / 221	257 / 221	257 / 221	257 / 221	257 / 221	265 / 229	265 / 229	257 / 221	257 / 221	261 / 225	257 / 221	257 / 221	265 / 229	265 / 229
Cat. No.	blood collection / urine tubes						tubes with screw cap				5127²⁴⁾	-²⁴⁾	0551²⁴⁾	0554²⁴⁾	

Adapter															
boring Ø x L in mm	17.5x70	13.2x32	17.5x32	13.2x70	16x70	17.5x70	17x70	30 x 70	17.5x70	26 x 70	30 x 96	62 x 90	62 x 90	94x105	97.5x105
vessels per rotor	180 / 120	180 / 120	180 / 120	180 / 120	150 / 100	180 / 120	138 / 92	48 / 32	96 / 64	66 / 44	36 / 24	6 / 4	6 / 4	6 / 4	6 / 4
Cat. No.	4214	4222-93	4214-93	4222	4223	4214	4232	4245-A	4220	4215	4249	4238	4238	4233	4258

Vessels				
capacity in ml	750	750	250	500
Ø x L in mm	97 x 152	96 x 135	60 x 162	96 x 147
max. RCF Rotor 4176 / 4174	5,999 / 5,184	5,999 / 5,184	5,818 / 5,003	5,999 / 5,184
radius in mm	265 / 229	265 / 229	257 / 221	265 / 229
Cat. No.	0512²⁴⁾	4234-A	Corning®	Corning®

Adapter				
boring Ø x L in mm	97.5x105	97.5x105	60x125	97.5x105
vessels per rotor	6 / 4	6 / 4	6 / 4	6 / 4
Cat. No.	4258	4258	6322	4258

- 1) For cooled versions: Lowest temperature achievable with precooling and max. speed.
- 2) Please note that the RCF values indicated refer only to rotor performance. The max. permissible RCF of tubes used should be verified with the individual manufacturers. The max. RCF for glass tubes annotated with footnote 2) is 4,000.
- 5) Tested by the TÜV in conformity with DIN EN 61010, section 2 - 020.
- 24) At temperatures of over +40 °C and / or when not filled to capacity, bottles may warp during centrifugation.

SWING-OUT ROTOR, 6- / 4-PLACE | 4176 / 4174

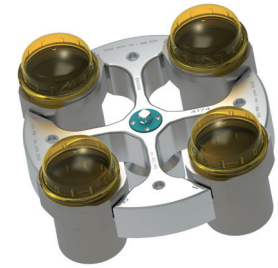
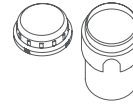

Rotor	
max. RPM	4,500 min ⁻¹
max. RCF Rotor 4176 / 4174	6,384 / 5,592
max. capacity	6 x 1,000 ml
run-up run-down, braked in sec	125 197
angle temperature in °C ¹⁾	90° +9 / -9
Cat. No.	4176 / 4174

Bucket	
lid	5621
Cat. No.	4547-B

Vessels															
capacity in ml	5	7	9	15	25	50	100	2.6-3.4	2.7-3	4-5.5	4.5-5	4.9	7.5-8.2	9-10	10
Ø x L in mm	12x75	12x100	14x100	17x100	24x100	34x100	44x100	13 x 65	11x66	15x75	11x92	13x90	15x92	16x92	15x102
max. RCF ²⁾ Rotor 4176 / 4174	5,841 / 5,026	5,841 / 5,026	5,977 / 5,184	5,977 / 5,184	5,728 / 4,913	5,773 / 4,981	5,750 / 4,958	5,841 / 5,026	5,841 / 5,026	5,977 / 5,184	5,841 / 5,026	5,841 / 5,026	5,977 / 5,184	5,977 / 5,184	5,977 / 5,184
radius in mm	258 / 222	258 / 222	264 / 229	264 / 229	253 / 217	255 / 220	254 / 219	258 / 222	258 / 222	264 / 229	258 / 222	258 / 222	264 / 229	264 / 229	264 / 229
Cat. No.	tubes²⁾							blood collection / urine tubes							

Adapter															
boring Ø x L in mm	13 x 58	13 x 58	17,5 x 60	17,5 x 60	26 x 72	36 x 79	45 x 78	13,5 x 58	13 x 58	17,5 x 60	13 x 58	13,5 x 58	17,5 x 60	17,5 x 60	17,5 x 60
vessels per rotor	180 / 120	180 / 120	114 / 76	114 / 76	42 / 28	24 / 16	12 / 8	126 / 84	180 / 120	114 / 76	180 / 120	126 / 84	114 / 76	114 / 76	114 / 76
Cat. No.	4433	4433	4434	4434	4438	4439	4442	4435	4433	4434	4433	4435	4434	4434	4434

Vessels															
capacity in ml	1.6-5	4-7	4-7	8	8.5-10	15	50	25	30	10	250	290	650	750	1.000
Ø x L in mm	13x75	13x100	16x75	16 x 125	16x100	17x120	29x115	25x90	25x110	16 x 80	62 x 122	62 x 137	97 x 139	97 x 152	96 x 176
max. RCF ²⁾ Rotor 4176 / 4174	5,841 / 5,026	5,841 / 5,026	5,977 / 5,184	5,977 / 5,184	5,977 / 5,184	6,090 / 5,298	6,090 / 4,958	5,909 / 5,117	5,909 / 5,117	5,977 / 5,184	6,203 / 5,411	6,203 / 5,411	6,384 / 5,592	6,384 / 5,592	6,384 / 5,592
radius in mm	258 / 222	258 / 222	264 / 229	264 / 229	264 / 229	269 / 234	269 / 219	261 / 226	261 / 226	264 / 229	274 / 239	274 / 239	282 / 247	282 / 247	282 / 247
Cat. No.	blood collection / urine tubes					tubes with screw cap					5127²⁴⁾	-²⁴⁾	0554²⁴⁾	0512²⁴⁾	4239²⁴⁾

Adapter															
boring Ø x L in mm	13,5 x 58	13,5 x 58	17,5 x 60	17,5 x 60	17,5 x 60	17 x 86	30 x 87	26 x 72	26 x 72	17,5 x 60	62x92	62x92	98 x 141	98 x 141	98 x 141
vessels per rotor	126 / 84	126 / 84	114 / 76	114 / 76	114 / 76	72 / 48	30 / 20	42 / 28	42 / 28	114 / 76	6 / 4	6 / 4	6 / 4	6 / 4	6 / 4
Cat. No.	4435	4435	4434	4434	4434	4437	4441	4438	4438	4434	4443	4443	-	-	-

Vessels						
capacity in ml	175	175	200	225	250	500
Ø x L in mm	61 x 118	61.5x144.3	60x130	61 x 137	60 x 162	96 x 147
max. RCF ²⁾ Rotor 4176 / 4174	6,384 / 5,592	6,384 / 5,592	6,384 / 5,592	6,384 / 5,592	6,384 / 5,592	6,384 / 5,592
radius in mm	282 / 247	282 / 247	282 / 247	282 / 247	282 / 247	282 / 247
Cat. No.	Falcon®	Nalgene®	Nunc®	Falcon®	Corning®	Corning®

Adapter						
boring Ø x L in mm	-	-	-	-	-	-
vessels per rotor	6 / 4	6 / 4	6 / 4	6 / 4	6 / 4	6 / 4
Cat. No.	4440	4430	4430	4440	4430	4449

- 1) For cooled versions: Lowest temperature achievable with precooling and max. speed.
- 2) Please note that the RCF values indicated refer only to rotor performance. The max. permissible RCF of tubes used should be verified with the individual manufacturers. The max. RCF for glass tubes annotated with footnote 2) is 4,000.
- 3.17) When using these tubes, bucket 4547-B cannot be closed with lid 5621.
- 24) At temperatures of over +40 °C and / or when not filled to capacity, bottles may warp during centrifugation.

— SWING-OUT ROTOR, 6- / 4-PLACE | 4176 / 4174



Rotor	
max. RPM	4,500 min ⁻¹
max. RCF	Rotor 4176 / 4174 5,999 / 5,184
max. capacity	6x750 ml
run-up run-down, braked in sec	125 197
angle temperature in °C ¹⁾	90° +14 / -1
Cat. No.	4176 / 4174



Bucket	
Cat. No.	4572

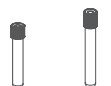

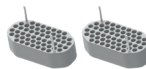

Vessels	
capacity in ml	4 – 7
Ø x L in mm	13x75 13x100
max. RCF	Rotor 4176 / 4174 5,818 / 5,003 5,818 / 5,003
radius in mm	257 / 221 257 / 221
Cat. No.	blood collection tubes



Adapter	
boring Ø x L in mm	13.2 x 59 13.2 x 59
vessels per rotor	336 / 224 336 / 224
Cat. No.	4493 4493

— ANGLE ROTOR, 6-PLACE | 4570













Rotor	
max. RPM max. RCF	6,000 min ⁻¹ 5,594
max. capacity	6x250 ml
run-up run-down, braked in sec	64 69
angle max. noise level	25° 54 dB(A)
temperature in °C ¹⁾	-16
Cat. No.	4570



Lid bioseal [®] and phenol-resistant	
Cat. No.	INCLUSIVE



Vessels											
capacity in ml	15	25	94	15	50	10	30	50	85	94	250
Ø x L in mm	17x100	24x100	38x102	17x120	29x115	16x80	26x95	29x107	38 x 106	38 x 102	61.5x122
max. RCF ²⁾	5,315	5,152	4,910	5,152	4,830	5,353	5,152	4,830	4,910	4,910	5,594
radius in mm	132	128	122	128	120	133	128	120	122	122	139
Cat. No.	tubes²⁾			tubes with screw cap							5127²⁴⁾

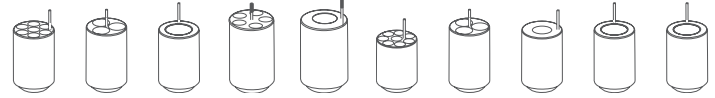

Adapter	
boring Ø x L in mm	17.6 x 83 26x80 38.6x88 17x106 30x100 16.6x70 26x80 29x90 38.6 x 88 38.6 x 88 61.5x109
vessels per rotor	42 18 6 30 6 48 18 6 6 6 6
Cat. No.	5646 5642 5644 5637 5638 5641 5642 5643 5644 5644 -

1) For cooled versions: Lowest temperature achievable with precooling and max. speed.
 2) Please note that the RCF values indicated refer only to rotor performance. The max. permissible RCF of tubes used should be verified with the individual manufacturers. The max. RCF for glass tubes annotated with footnote 2) is 4,000.
 5) Tested by the TÜV in conformity with DIN EN 61010, section 2 - 020.
 24) At temperatures of over +40 °C and / or when not filled to capacity, bottles may warp during centrifugation.

ACCESSORIES FOR CENTRIFUGING BLOOD BAG SYSTEMS



Hettliner

Blood bags can be secured in adapters using HettLiners. After centrifuging, they can be removed by their loops without disturbing the delicate separation of blood components.

Cat. No. 4564

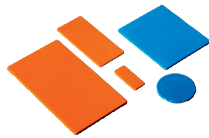

Set of compensatory weights

If blood bag carriers are not filled to the same weight, then compensatory weights can be used to make up the difference. One set includes:
 40 balancing weights, 2 g each;
 20 balancing weights, 5 g each;
 10 balancing weights, 10 g each;
 5 balancing weights, 20 g each;
 5 balancing weights, 40 g each

Cat. No. 4566



Balancing inserts

In case there are not enough blood bag systems to occupy every carrier of the rotor, empty carriers can be filled with balancing inserts. Taring weights supplied with the inserts may be used for fine balancing.

4584-A for insert 4559-A

4587-A for insert 4592-B

4589-A for insert 4516-A



Loading station

Secure your samples and avoid accidental spillage with the convenient Loading Station for centrifuge inserts. The Hettich Loading Station allows users to confidently hold and manage their samples without the risk of the inserts toppling over.

Cat. No. 4509

CERTIFICATIONS / REGISTRATIONS

Product certification:



Product registration:



Company certifications:



DIMENSIONS

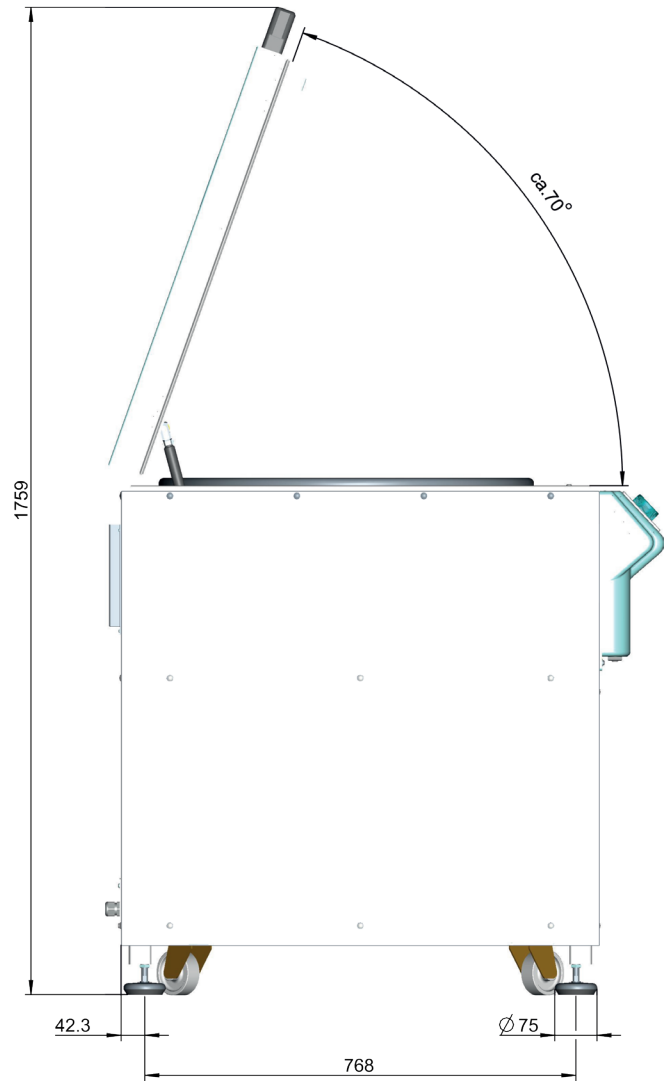
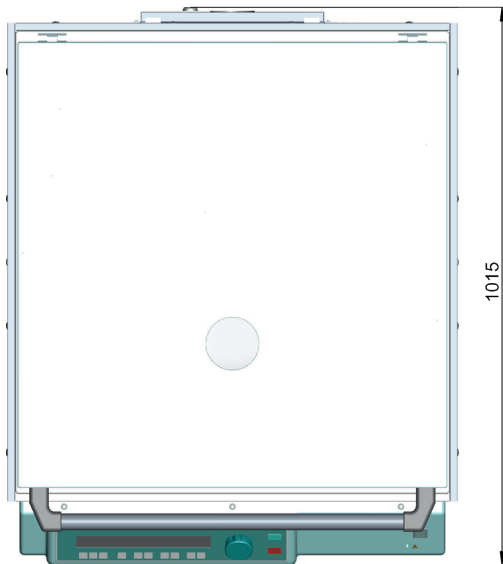
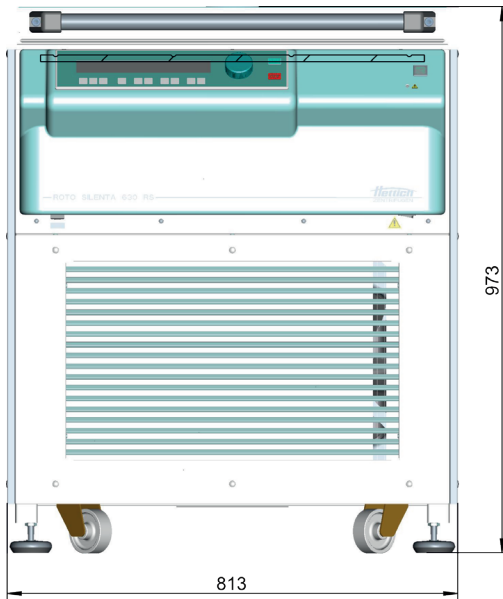



WolfLabs

Pricing on any accessories shown can be found by keying the part number into the search box on our website.

The specifications listed in this brochure are subject to change by the manufacturer and therefore cannot be guaranteed to be correct. If there are aspects of the specification that must be guaranteed, please provide these to our sales team so that details can be confirmed.

www.wolflabs.co.uk

Tel : 01759 301142

Fax : 01759 301143

sales@wolflabs.co.uk

Please contact us if this literature doesn't answer all your questions.