

# Cole-Parmer®

## SC-200 Series

### Sample Concentrator

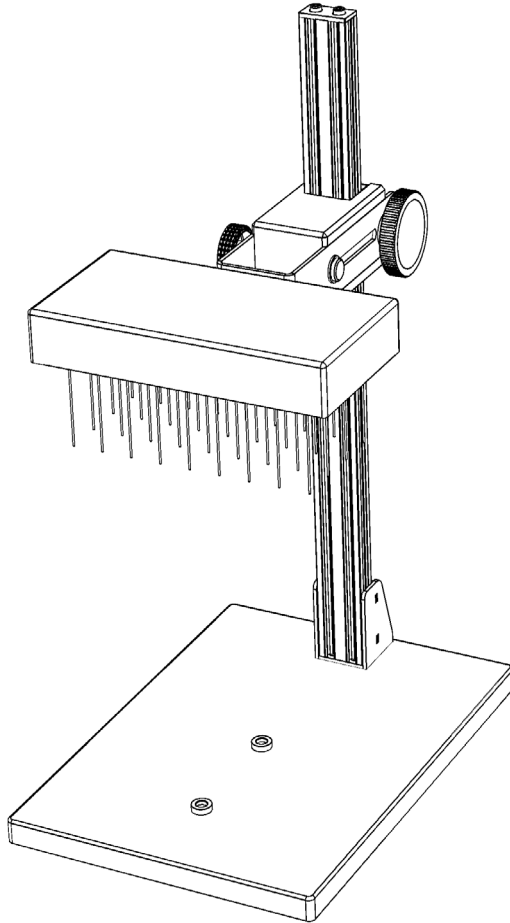

Instruction Manual  
070-015 / Version 1.0

**Cole-Parmer®**  
essentials



## Contents

<b>Introduction</b>	<b>4</b>
<b>General Description</b>	<b>4</b>
<b>Important Safety Advice</b>	<b>4</b>
<b>Installation</b>	<b>5</b>
<b>Operation</b>	<b>8</b>
Preparation	8
Processing of Samples	10
<b>Maintenance</b>	<b>10</b>
Cleaning and Care	10
Carriage Friction	10
Replacing Sealing Pad	10
In Case of Contamination	11
<b>Service and Repair</b>	<b>11</b>
Replacement Parts and Accessories	12
<b>Diagram of Gas Chamber</b>	<b>12</b>
<b>Technical Specification</b>	<b>13</b>
<b>Customer and Technical Support</b>	<b>13</b>
<b>Solvent Evaporation Temperatures</b>	<b>14</b>

## Introduction

Thank you for purchasing this Cole-Parmer product. To get the best performance from the equipment, and for your own safety, please read these instructions carefully before use.

Before discarding the packaging check that all parts are present and correct.

When unpacking the unit, check that the following have been removed from the packing:

- ❖ Base board
- ❖ Column
- ❖ Carriage
- ❖ Gas chamber
- ❖ Bag of fasteners
- ❖ Instruction manual

## General Description

The Cole-Parmer Sample Concentrator has been designed to provide a quick and convenient method of accelerating the concentration by evaporation of solvents from samples prior to analysis. It is designed to work in conjunction with Cole-Parmer BH-250D-3, BH-250D-3-HT, BH-250-3, and BH-250-3-HT Block Heaters\*.

The Sample Concentrator consists of a gas chamber mounted above a Block Heater into which vessels containing samples are placed. Hypodermic needles carry the gas down from the chamber into the test tubes. The samples are heated from below by the heater and the flow of gas directed over the surface of the samples displaces the evaporated solvent from above the liquid's surface. This significantly increases the rate of sample concentration.

The unit provides accurate and reproducible control over the positioning of the needles. The gas chamber can be removed from its stand to provide easy access to the samples, and it can be replaced quickly. The whole unit is compact enough for convenient use in a fume cupboard.

\* The Block Heater is not provided and must be purchased separately.

## Important Safety Advice

Users should be aware of the following safety advice:

- ❖ **DO NOT** use combustible substances near hot objects.
- ❖ **DO NOT** use the equipment in hazardous atmospheres.
- ❖ **HIGH TEMPERATURES ARE DANGEROUS** as they can cause serious burns to operators and ignite combustible material.
- ❖ **USE CARE AND WEAR PROTECTIVE GLOVES TO PROTECT HANDS.**
- ❖ **DO NOT** apply severe physical stress or use at temperatures above the rated value.



# Symbols Defined

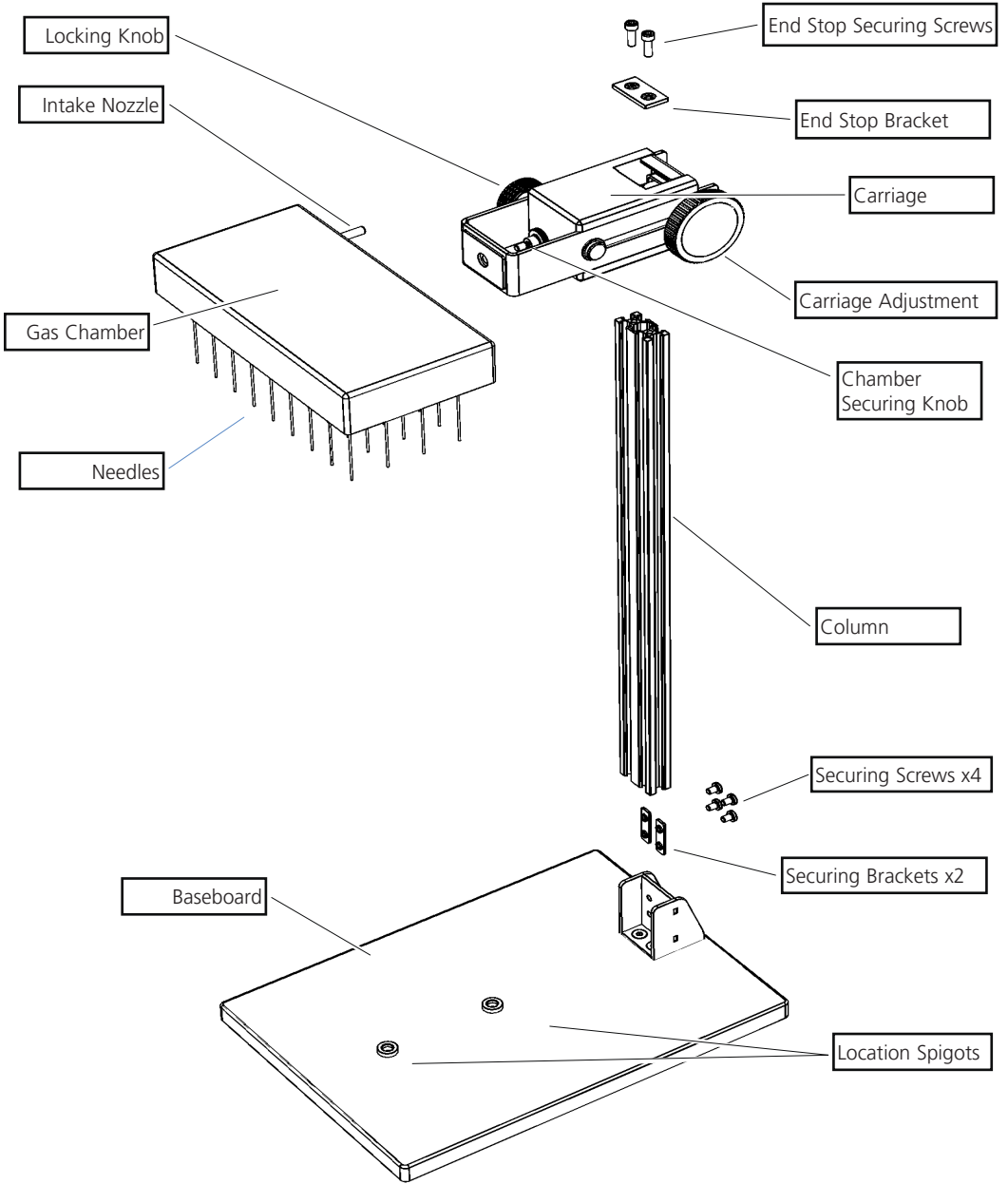

# Installation

Exploded view

For packing purposes the Sample Concentrator is supplied unassembled in four parts;

- ❖ Base board
- ❖ Column
- ❖ Carriage
- ❖ Gas chamber

The unit is re-assembled as follows:

1. Slide the x2 Securing Brackets into the Column with the flat faces orientated towards the rear.

Insert the Column into the Baseboard and secure using the x4 Securing Screws.

*It is recommended to lay the Column on the edge of a flat surface to line up the fixing holes.*

*Loosely fit the Securing Screws in place. With both sections supported, carefully stand the assembly upright and ensure the Column is sitting flush with the Baseboard before fully tightening.*

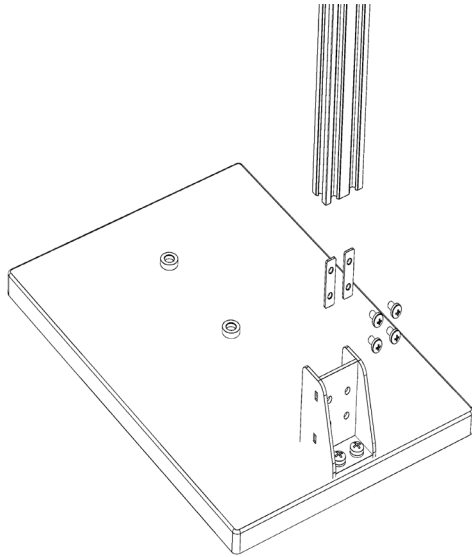

2. Remove the End Stop Bracket and Securing Screws.



5. Slide the Carriage over the Column and replace the previously removed bracket and screws. Tension of the Carriage can be adjusted by tightening/slackening the nylon screw located at the rear.

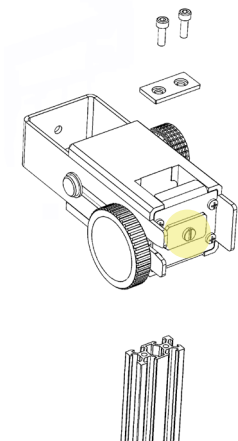

6. Attached the Gas Chamber to the Carriage using the Chamber Securing Screw.

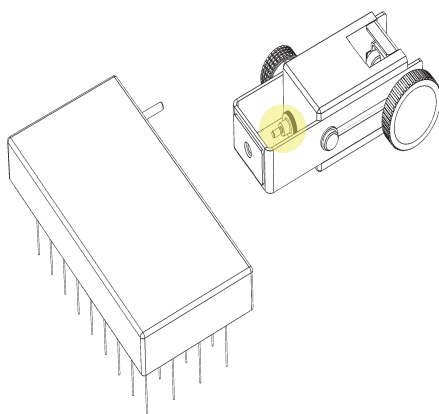

# Operation

## Preparation

1. Place the aluminium insert blocks to be used into the Cole-Parmer Block Heater unit. The blocks should touch each other and be positioned centrally.
2. Loosen the locking knob on the carriage. Remove the gas chamber, disconnecting the gas pipe if necessary, and lay the chamber upside down on a suitable work surface.
3. Insert the hypodermic needles in the pattern to suit the test tubes to be placed in the heater.

The needle guide holes are labelled with a letter corresponding with the type of insert block used in the heater. These are listed in the following table. As an example if you use the block for twelve 15mm test tubes (e.g. block number F3506) you would place a needle in all the holes labelled C.

Only Sample Concentrators with the part number SC-200-96 or a replacement head part number 6106467 will have the 96 well array.

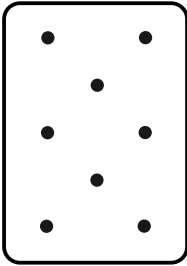
<i>Tube size &amp; diameter</i>	<i>Hole array</i>	<i>Hole label</i>
5 x 6 deep	30	A
4 x 5 deep	20	B
3 x 4 deep	12	C
8 hole off-set array, e.g. F4490 		D

Press each needle firmly, pointed end first, through the guide holes and through the sealing pad behind so that it is held firmly in position. Build up the desired pattern of needles to suit the arrangement of test tubes to be used. Do not put a needle in any position which will not have a corresponding sample to be concentrated as this will only waste gas. The needles may be removed and replaced many times as the pad is self sealing.

4. Replace the gas chamber onto the carriage and tighten the locking knob. Re-connect the gas pipe if necessary.

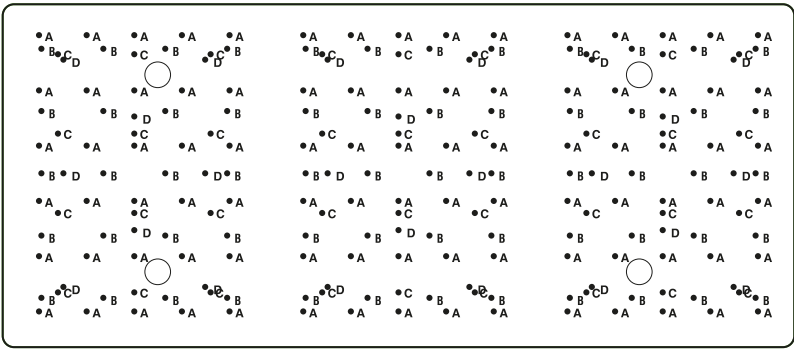

SC-200 matrix plate

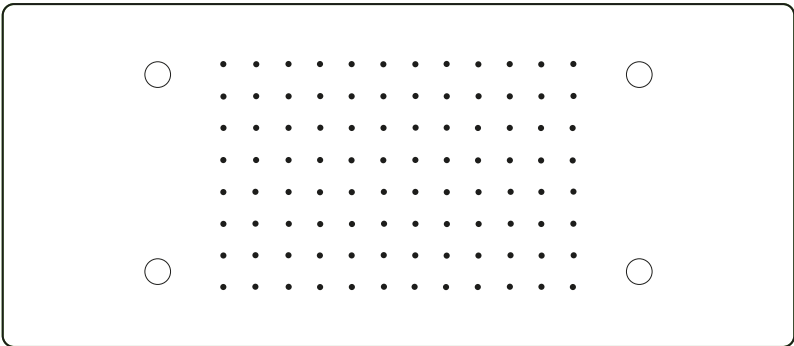

SC-200-96 matrix plate

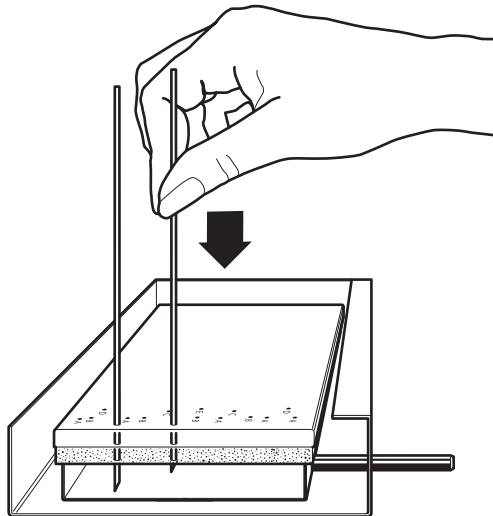

Inserting the Needles

## Processing of Samples



**Warning** - remember high temperatures are dangerous. The heater, insert blocks, sample vessels, needles and samples may be very hot. Always take the precautions listed earlier in this manual.

1. By turning the carriage knob, on the right hand side, counter clockwise raise the gas chamber to take the needles well away from the heater.
2. Place the sample vessels in the insert blocks and lower the chamber so that the tips of the needles enter the test tubes. Position them at the required height above the liquid surface.
3. Set the heater to the required temperature and adjust the gas flow to the desired rate. Remember not to exceed 2 psi.
4. To increase the rate of concentration the chamber may be lowered as evaporation takes place so that the needles follow the level of the samples in the tubes.
5. On completion switch off the gas flow and raise the chamber out of the way.
6. For operation of the Block Heater see the user's manual supplied separately.

## Maintenance

### Cleaning and Care



With proper care and operation, the equipment should give reliable service, however contamination or general misuse may reduce the effective life of the product and could cause a hazard.

Preventative maintenance should include keeping the product clean by protecting it from spillage, contamination or corrosive environments. If in doubt, please confirm that any intended method of decontamination will not damage the equipment by contacting Antylia Scientific.

Your Sample Concentrator can be cleaned by wiping with a cloth dipped in soapy water. Ethanol and formaldehyde may also be used.

**NOTE:** Do not use solvents or abrasive cleaners for cleaning any parts of this equipment.

### Carriage Friction

Height adjustment is by means of a friction drive. To allow for wear the friction pressure may be increased by tightening the screw on the rear of the carriage sufficiently to give adequate grip.

### Replacing Sealing Pad

After many repeated needle insertions the self sealing property of the sealing pad may start to degrade. Spare pads can be obtained from your supplier or from Antylia Scientific. Replacing the pad is simply accomplished as follows:

- ❖ Remove the gas chamber from the carriage, disconnect the gas pipe and place upside down on a suitable work surface.
- ❖ Remove the four screws securing the matrix plate.
- ❖ Lift off the matrix plate.
- ❖ Lift off the sealing pad. Ensure that the support strip underneath the sealing pad remains in place.
- ❖ Replace the sealing pad with the new one. Reassembly is the reverse of the above procedure.

## In Case of Contamination



**WARNING: THE FOLLOWING PROCEDURE IS INTENDED AS A GUIDE. SHOULD SPILLAGE OF A TOXIC OR HAZARDOUS FLUID OCCUR, THEN ADDITIONAL SPECIAL PRECAUTIONS MAY BE NECESSARY.**

If the equipment has been exposed to contamination, the Responsible Body is responsible for carrying out appropriate decontamination. If hazardous material has been spilt on or inside the equipment, decontamination should only be undertaken under the control of the Responsible Body with due recognition of possible hazards. Before using any cleaning or decontamination method, the Responsible Body should check with the manufacturer that the proposed method will not damage the equipment. Prior to further use, the Responsible Body shall check the electrical safety of the unit. Only if all safety requirements are met can the unit be used again.

**NOTE:** In the event of this equipment or any part of the unit becoming damaged or requiring service, the item(s) should be returned to the manufacturer for repair accompanied by a decontamination certificate. Copies of the Certificate are available from the Distributor/Manufacturer.

At the end of its service life, the product must be accompanied by a Decontamination Certificate.

## Servicing and Repair

This product range does not require any routine servicing, instructions for cleaning and decontamination are included.

In the event of product failure, it is recommended that any repair is only undertaken by suitably qualified personnel. For advice, please contact Antylia Scientific quoting the model and serial number.

Only spare parts supplied by the manufacturer or its agent should be used. Fitting of non-approved parts may affect the performance of the safety features of the instrument.

If in doubt, please contact:

Antylia Scientific Ltd.  
Beacon Road,  
Stone, Staffordshire,  
ST15 0SA, United Kingdom  
Tel: +44 (0)1785 812121  
Email: cpservice@antylia.com  
Web: www.coleparmer.com

## Replacement Parts and Accessories

The following replacement parts and accessories may be obtained from your supplier or from Antylia Scientific.

Part Number	Description
F7209	Pack of 100 x 76mm long needles
F7210	Pack of 100 x 127mm long needles
FSC4NCS	Pack of PTFE coated needles, 100 x 76mm long
FSC4NCL	Pack of PTFE coated needles, 100 x 127mm long
6101608	Spigot
6101604	Sealing pad
6101605	Support strip
6106410	Standard, three block, matrix plate
6106467	96 well matrix plate
SC-200	Standard, three block, matrix
SC-200-96	96 well matrix

## Diagram of Gas Chamber

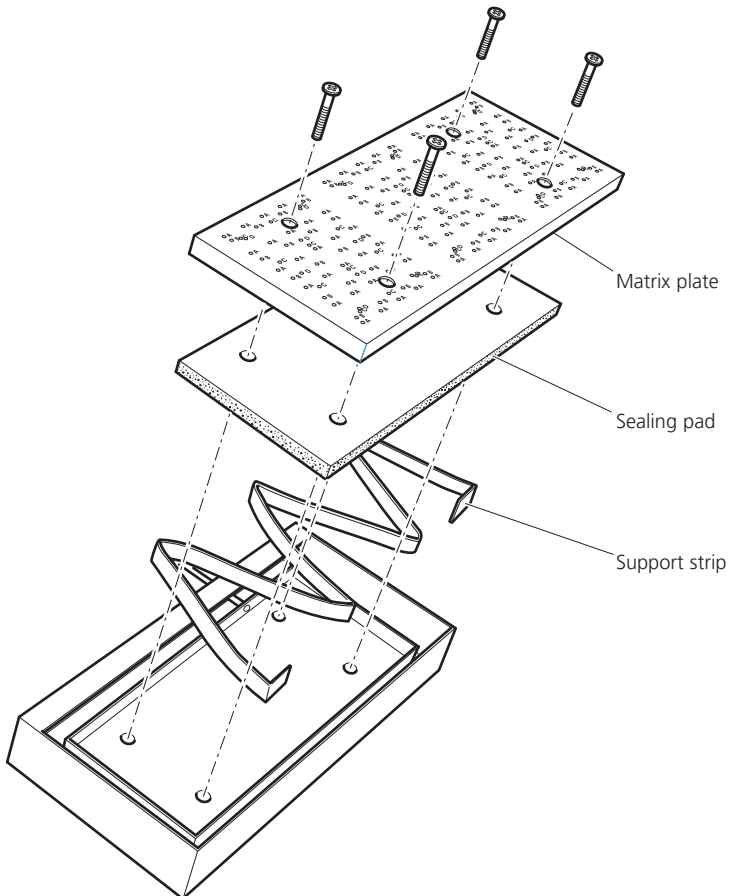

## Technical Specification

---

Maximum vertical travel	370 mm
Maximum gas pressure	2 psi
Maximum gas usage	15 litres/min
Gas	Any inert gas (often nitrogen)
Needle positions	Variable to suit Cole-Parmer Block Heater
Gas intake nozzle diameter	6.35 mm (¼")
Height	540 mm
Width	265 mm
Depth	370 mm
Weight	3.5 Kg

---

## Customer and Technical Support

For help and support, contact:

Antylia Scientific Ltd.

Beacon Road,

Stone, Staffordshire,

ST15 0SA, United Kingdom

Tel: +44 (0)1785 812121

Customer Services: [cpinfo@antylia.com](mailto:cpinfo@antylia.com)

Sales: [cpsales@antylia.com](mailto:cpsales@antylia.com)

Technical Support: [cptechsupport@antylia.com](mailto:cptechsupport@antylia.com)

Warranty, Repairs and Service: [cpservice@antylia.com](mailto:cpservice@antylia.com)

Web: [www.coleparmer.com](http://www.coleparmer.com)

## Solvent Evaporation Temperatures

IUPAC Name	Common Name	Boiling point (°C) at 1013 mbar pressure	Pressure (mbar) at which b.p is 40 °C
2-Propanone	Acetone	56	556
1-Pentanol	Pentyl alcohol	137	11
Benzene	Benzene	80	236
1-Butanol	Butyl alcohol	118	25
2-Methyl-2-propanol	Tert-butyl alcohol	83	130
Chlorobenzene	Chlorobenzene	132	36
Chloroform	Trichloromethane	61	474
Cyclohexane	Cyclohexane	81	235
Ethoxyethane	Diethyl ether	35	Atmospheric
1,2-Dichloroethane	Ethylene chloride	83	210
1,2-Dichloroethene	Cis-acetylene dichloride	60	479
1,2-Dichloroethene	Trans-acetylene dichloride	48	751
2-Propan-2-yloxypropane	Isopropyl ether	68	375
1,4-Dioxane	Diethylene oxide	101	107
N,N-dimethylformamide	Dimethylformamide (DMF)	153	11
Acetic acid	Ethanoic acid	118	44
Ethanol	Alcohol	79	175
Ethyl acetate	Ethyl ester	77	40
Heptane	Dipropylmethane	98	120
Hexane	n-Hexane	69	335
Propan-2-ol	Isopropanol	82	137
3-Methyl-1-butanol	Isoamyl alcohol	130	14
Butan-2-one	Methylethylketone (MEK)	80	243
Methanol	Methyl alcohol	65	337
Dichloromethane	Methylene chloride	40	Atmospheric
Pentane	Pentane	36	Atmospheric
Propan-1-ol	Propyl alcohol	97	67
1,1,1,2,2-Pentachloroethane	Pentachloroethane	162	13
1,1,2,2-Tetrachloroethane	Tetrachloroethane	138	35
1,1,1-Trichloroethane	Trichloroethane	75	271
Tetrachloromethane	Carbon tetrachloride	76	300
1,1,2,2-Tetrachloroethene	Tetrachloroethylene	121	53
Oxolane	Tetrahydrofuran (THF)	67	357
Toluene	Methylbenzene	111	77
1,1,2-Trichloroethene	Trichloroethylene	87	183
Oxidane	Water	100	72
Dimethylbenzene	Xylene (mixed)	137	25
1,2-Dimethylbenzene	o-Xylene	144	34
1,3-Dimethylbenzene	m-Xylene	139	25
1,4-Dimethylbenzene	p-Xylene	138	31





# WolfLabs

**Pricing on any accessories shown can be found by keying the part number into the search box on our website.**

The specifications listed in this brochure are subject to change by the manufacturer and therefore cannot be guaranteed to be correct. If there are aspects of the specification that must be guaranteed, please provide these to our sales team so that details can be confirmed.

**[www.wolflabs.co.uk](http://www.wolflabs.co.uk)**

**Tel : 01759 301142**

**Fax : 01759 301143**

**[sales@wolflabs.co.uk](mailto:sales@wolflabs.co.uk)**

Please contact us if this literature doesn't answer all your questions.